



<https://cleanfix.org/instruction>

- EN: Scan QR code to get instructions in other languages.
DE: QR-Code scannen um Anleitung in weiteren Sprachen zu erhalten.
FR: Scanner le code QR pour obtenir des instructions dans d'autres langues.
IT: Scansione QR-Code per ottenere istruzioni in altre lingue.
ES: Escanea el Código QR para obtener instrucciones en otros idiomas.
PT: Digitalize o Código QR para obter instruções noutras línguas.
TR: Diğer dillerdeki talimatlar için QR kodunu tarayın.



Thank you for choosing the Cleanfix® reversible fan.

Only Cleanfix® reversible fans rotate their fan blades around over the cross position at the touch of a button and effectively clean radiators and screens. Drive power is reduced thanks to the clean radiator and improved cooling. As a result, more power is available simultaneously at the power take-off shaft and at the wheels, and less fuel is consumed.

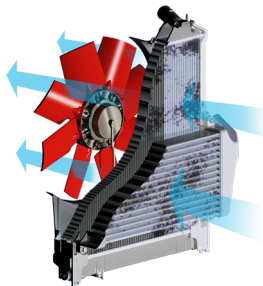

EFFICIENT COOLING

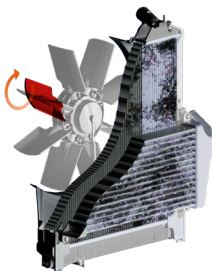

**REVERSING OVER THE
CROSS POSITION**

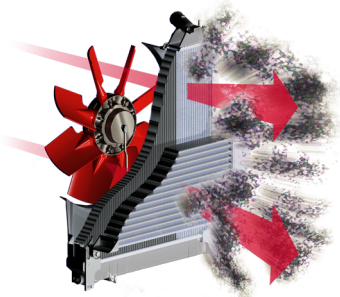

HIGH-PRESSURE



CONTROL VIA APP

Functions such as radiator cleaning, settings, system check, and many more can be performed easily via the Cleanfix control app.



MORE POWER

Cleanfix® reversible fans increase power by up to 27 hp and thus deliver more punch.



INCREASED PRODUCTIVITY

Cleanfix® reversible fans clean at full speed without interruption of work.



FUEL SAVINGS

Cleanfix® reversible fans keep radiators clean and save up to 4 kW compared with dirty radiators.



LESS DOWNTIME

Cleanfix® reversible fans lengthen the maintenance and cleaning intervals.



OPTIMIZED COOLING

Cleanfix® reversible fans adapt their blade angle to the cooling requirements.



POWERFUL CLEANING

Cleanfix® reversible fans automatically blow dirt out of the radiator at a configurable time interval.

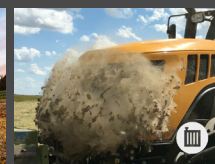
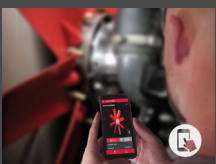

Contents

1	General information	5
1.1	Legal notice.....	5
1.1.1	Copyright.....	5
1.1.2	Service address.....	5
1.1.3	Current operating instructions.....	5
1.2	Introduction.....	6
1.2.1	Target group.....	6
1.2.2	Liability and damages.....	6
1.2.3	Product identification.....	7
1.3	Product description.....	8
1.3.1	Pneumatic fan components.....	8
1.3.2	Hydraulic fan components.....	9
1.3.3	Electronic components without timer.....	10
1.3.4	Electronic components with timer.....	10
2	Safety	11
2.1	Intended use.....	11
2.2	Foreseeable misuse.....	11
2.3	General safety information.....	12
3	Required tools	14
4	Removing the original fan	15
5	Installing the Cleanfix fan	16
5.1	Preparing the shroud.....	16
5.2	Installing the pressure hose.....	18
5.3	Installing the flange.....	20
5.4	Measuring the axial and radial runout.....	21
5.5	Installing the fan.....	22
5.6	Tensioning the pressure hose.....	25
5.7	Precluding collision.....	26
5.7.1	Pneumatic fan.....	26
5.7.2	Hydraulic fan.....	27
5.8	Installing the fitting on the pressure hose (H162).....	28
6	Installing the electronics	29
6.1	Installing electronic components.....	29
6.1.1	Installation dimensions.....	30
6.1.2	Installation overview.....	32
6.2	Installing the push button (optional).....	35

6.3	Connecting the electronic component to the power supply.....	36
7	Installing the pressure hose (pneumatic fans)	39
7.1	Connecting the electronic component to the fan	39
7.2	Connecting the electronic component to the compressed air system.....	39
8	Installing the pressure hose (hydraulic fans).....	40
8.1	Connecting the electronic component to the fan	40
8.2	Connecting the electronic component to the hydraulic system	40
9	Initial start-up	41
10	Operation (push button)	42
11	Operation (Cleanfix control app).....	44
11.1	Downloading the app	45
11.2	Pairing the device.....	46
11.3	Editing the device	49
11.4	Performing a system check	49
11.5	Performing manual cleaning	51
11.6	Turning automatic operation on/off.....	51
11.7	Removing a device.....	52
11.8	Showing the air filter status	52
12	Maintenance.....	53
12.1	Servicing the fan.....	53
12.2	Servicing the electronic components.....	53
13	Troubleshooting (fans)	54
13.1	Blades do not rotate to the cleaning position.....	54
13.2	Blades do not rotate to the cooling position.....	56
14	Troubleshooting (electronic components).....	57

1 General information

1.1 Legal notice

1.1.1 Copyright

TRANSLATED OPERATING INSTRUCTIONS

The copyright is owned by Hägele GmbH.
All rights reserved.

The contents of these operating instructions may be changed without notice.
Subject to change.

© Hägele GmbH 2022

1.1.2 Service address



Head office in Germany

Hägele GmbH

Am Niederfeld 13

DE-73614 Schorndorf
Germany

Tel.: +49 7181 96988 -36

Fax: +49 7181 96988 -80

E-Mail: service@cleanfix.org

Website: <http://www.cleanfix.org>

Branch in Canada

Cleanfix North America Inc.

250 Wright Blvd.

Stratford, Ontario
Canada N4Z 1H3

Tel.: +1 519 275 2808

Fax: +1 519 275 3995

E-Mail: cleanfix-ca@cleanfix.org

Website: <http://www.cleanfix.org>

Cleanfix distributors worldwide:
<https://cleanfix.org/en/contact/sales-international>

1.1.3 Current operating instructions

The current version of the operating instructions and other information are available at <https://cleanfix.org/instructions> or in the Cleanfix control app (see chapter 11).

1.2 Introduction

Before installing the Cleanfix kits, familiarize yourself with the contents of these operating instructions.

The operating instructions are a component of the product and must be stored close at hand.

1.2.1 Target group

These operating instructions are intended exclusively for mechanics trained on commercial machines.

The product may be installed and started up only by qualified personnel who are familiar with the operating instructions, the product, as well as the national laws and regulations concerning work, safety, and accident prevention.

1.2.2 Liability and damages

During installation, it may be necessary to make modifications to the machine. Hägele GmbH does not assume responsibility for modification and installation costs.

Hägele GmbH does not accept any liability for the following:

- direct damages or indirect losses arising from improper operation or maintenance.
- personal injury or property damage caused by untrained personnel or through failure to comply with regulations concerning work, safety, and accident prevention.

The operating instructions contain exemplary illustrations as well as optional features. The product may sometimes differ from the descriptions and depictions.

Check the delivered product for transport damage and completeness before installation:

- Immediately document in writing any defects and damage.
- Photograph damaged parts.
- Send a written damage report to customer service.

As a general principle, unauthorized modifications, alterations, or improper use exempt the manufacturer from liability for resulting damages.

1.2.3 Product identification

The following information is required for inquiries to the manufacturer:

A) Fan serial number

Serial number:

--	--	--	--	--	--

The serial number is found on the side edge of the front housing.

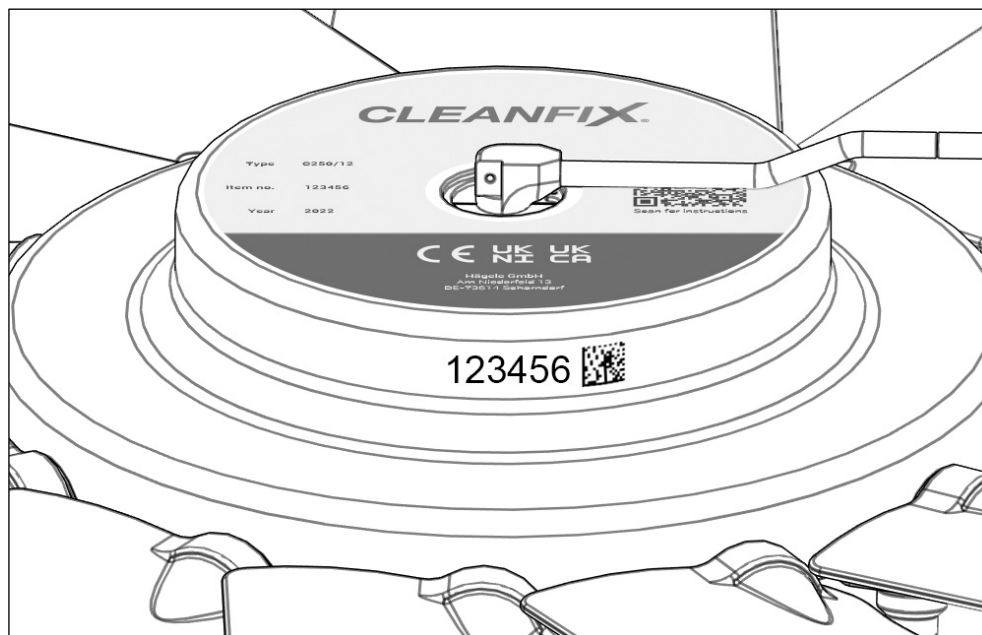

Fig. 1

B) Machine data

Manufacturer:

Model:

Operating hours:

C) Photo of the fan

Send in a photo of the fan.

Service address: See section 1.1.2

1.3 Product description

1.3.1 Pneumatic fan components

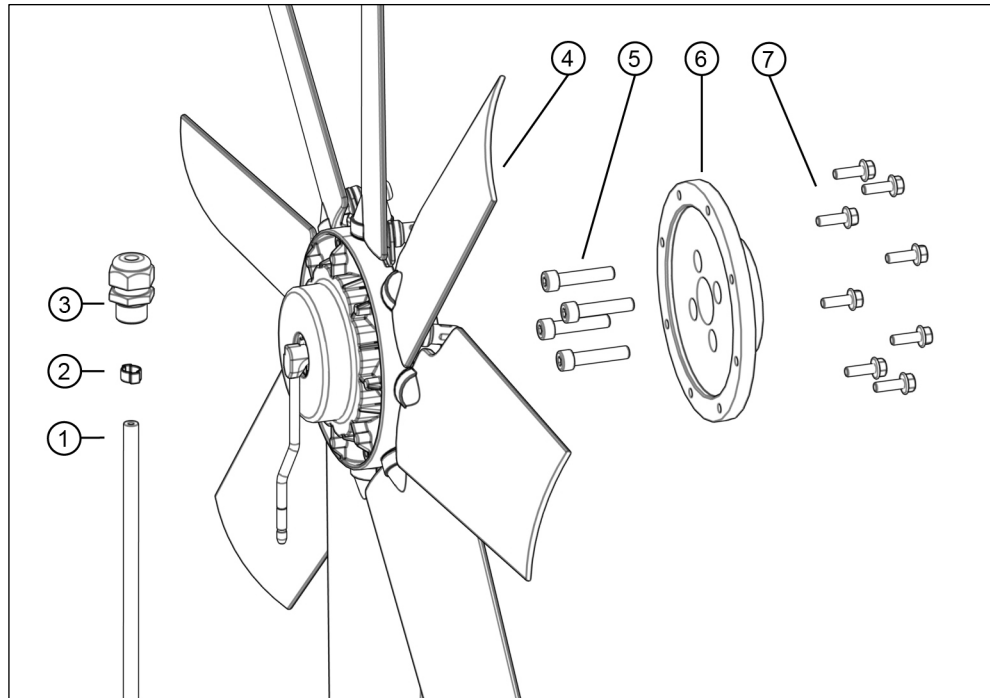

Fig. 2

- (1) Pressure hose
- (2) Hose clamp
- (3) Strain relief
- (4) Fan
- (5) Flange screws
- (6) Flange
- (7) Mounting screws

1.3.2 Hydraulic fan components

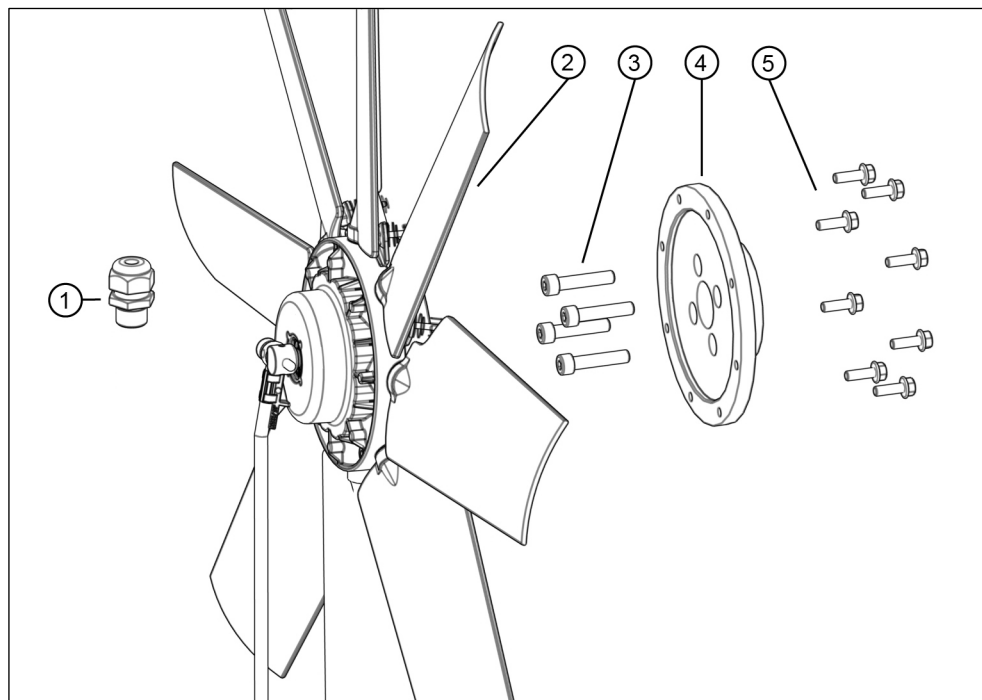
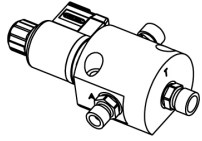
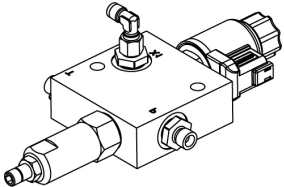
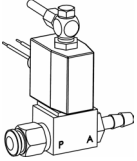

Fig. 3

- (1) Strain relief
- (2) Fan
- (3) Flange screws
- (4) Flange
- (5) Mounting screws

1.3.3 Electronic components without timer

Hydraulic activation		Pneumatic activation
With a hydraulic system in the machine		With a compressed air system in the machine
Valve  Fig. 4	Combi block - Valve  Fig. 5	Valve  Fig. 6

1.3.4 Electronic components with timer

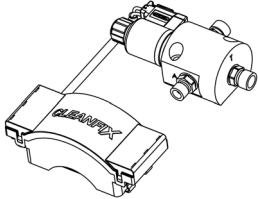
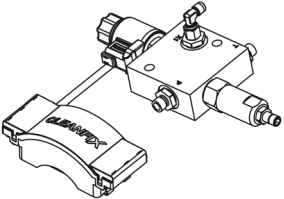
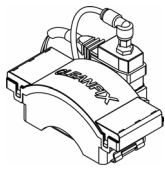
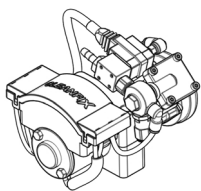
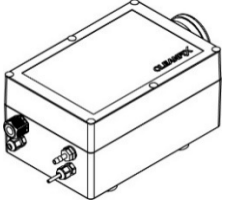
Hydraulic activation		Pneumatic activation	
With a hydraulic system in the machine		With a compressed air system in the machine	Without a compressed air system in the machine
Valve unit  Fig. 7	Combi block - Valve unit  Fig. 8	Valve unit  Fig. 9	Control unit  Fig. 10 E-Box  Fig. 11

2 Safety

2.1 Intended use

This product is used to cool and clean the radiators and the intake screens of commercial machines by generating an air flow. In the process, the blades rotate around their own axes and reverse the direction of flow. The fan can be switched manually or automatically. The various models differ in blade angle, direction of flow, and diameter.

The product may be used for the following purposes:

- For cooling commercial machines.
- For cleaning the radiators of commercial machines.

2.2 Foreseeable misuse

- Use of the fan in a way that is not intended by the manufacturer.
- Installation of the fan directly on the crankshaft or driving of the fan using a spur gear.
- Products other than those indicated and tested by the manufacturer are used in the commercial machine.
- Chopping of any type of materials.

2.3 General safety information

The following **WARNING!** safety information warns of a dangerous situation in which failure to observe the warning may result in death or major irreversible injury.

 WARNING!

Working on a machine while it is running may result in serious injury or death!

Objects or persons may be caught, pulled in, or crushed.

- ▶ Turn off the engine.
- ▶ Remove the ignition key.
- ▶ Disconnect the ground cable from the battery.
- ▶ Hang a "Do not operate" sign on the machine.

Rolling of the machine may result in serious injury or death!

An unsecured machine can run over or crush bystanders.

- ▶ Secure the machine against rolling.

The following **CAUTION!** safety information warns of a dangerous situation in which failure to observe the warning may result in slight to moderate injury.

 CAUTION!

Parts under pressure may cause injuries!

Injuries may occur during work on pneumatic and hydraulic parts.

- ▶ Only qualified personnel may perform work on parts under pressure.

Noise may cause injuries!

When work is performed in the immediate vicinity of the fan, the noise level may exceed 85 dB. This may lead to hearing loss.

- ▶ Wear ear protection.
-

The following **NOTE** safety information warns of situations in which failure to observe the warning may result in damage.

NOTE**Aging of the hydraulic hose lines may cause damage!**

Hydraulic hose lines are subject to natural aging that reduces the material's performance.

- ▶ For normal requirements, the recommended replacement interval is six years (see German Social Accident Insurance (DGUV) Rule 113-020 / as of 2022).

Moist compressed air may cause damage!

If compressed air is moist, water enters the pneumatic system and may damage mechanical parts such as the piston.

- ▶ Use only dry compressed air.
- ▶ If necessary, install a water separator.

The individual chapters of the operating instructions contain further safety information that must also be observed.

3 Required tools

Pressure hose installation

- Lubricant
- Pincers (hose clamp pincers) for hose clamp
- Standard tools for pressure hose fitting

Flange installation

- Dial gauge with magnetic base holder
- 10 Nm – 80 Nm torque wrench

Fan installation

- Cordless screwdriver
- 12 Nm – 20 Nm torque wrench
- Locking pliers (for example, vise grip) for clamping the pressure hose
- 20 mm (0.787") drill or step drill

Installation of fitting on pressure hose (H162)

- 10 mm (0,393") wrench
- 12 mm (0,472") wrench

Electronic component installation and connection

- Cordless screwdriver
- 22 mm (0.866") drill or step drill
- Standard power and hand tools

4 Removing the original fan



CAUTION!

Injuries due to a hot engine!

A hot engine can burn hands or other body parts

- ▶ Allow the engine to cool down.

- 1) Remove components to gain access to the original fan.
- 2) Remove the original fan.
- 3) Remove other components as required.



Read and observe the machine manufacturer's manual before removing the original fan.

5 Installing the Cleanfix fan

NOTE

Installing the fan on the crankshaft or using a spur gear to drive the fan may cause damage!

Torsional vibrations from the crankshaft or the spur gear may cause damage to the machine and to the fan.

- ▶ Install Cleanfix vibration dampers between the fan and crankshaft or spur gear.

5.1 Preparing the shroud

- 4) Drill a hole (20 mm / 0.787") as close as possible to the radiator.



Hole position

On the right or left side in the lower part of the shroud as close as possible to the radiator (Fig. 12).

- 5) Insert the strain relief into the hole from the outside.
- 6) Secure the strain relief from the inside using the nut.

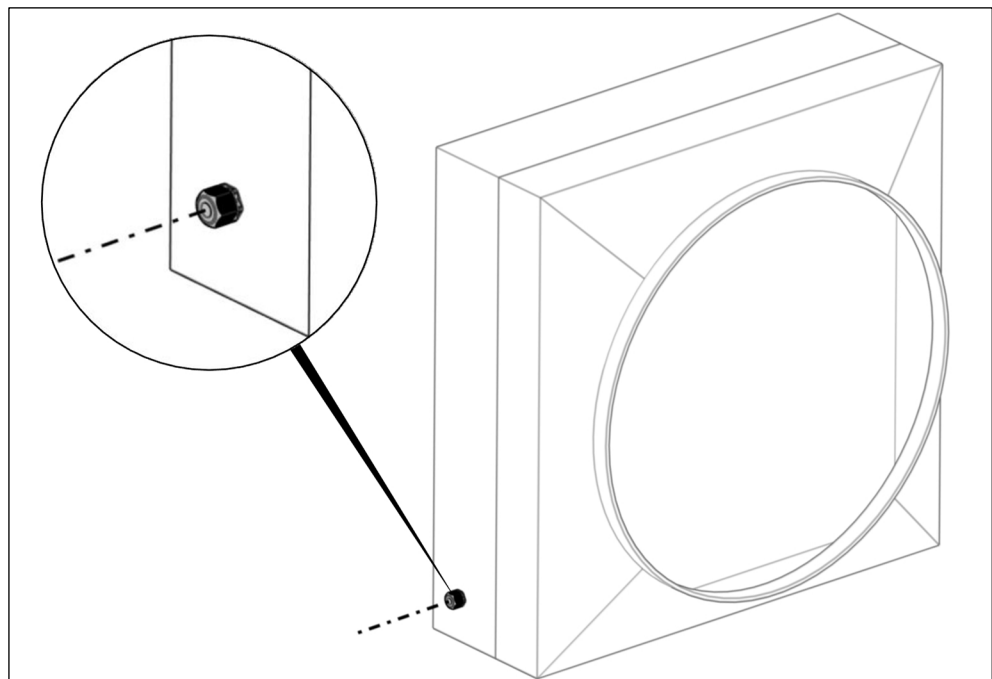

Fig. 12

**Optional: sheet metal ring**

Depending on the machine design, a sheet metal ring may be included in the scope of delivery and must also be installed.

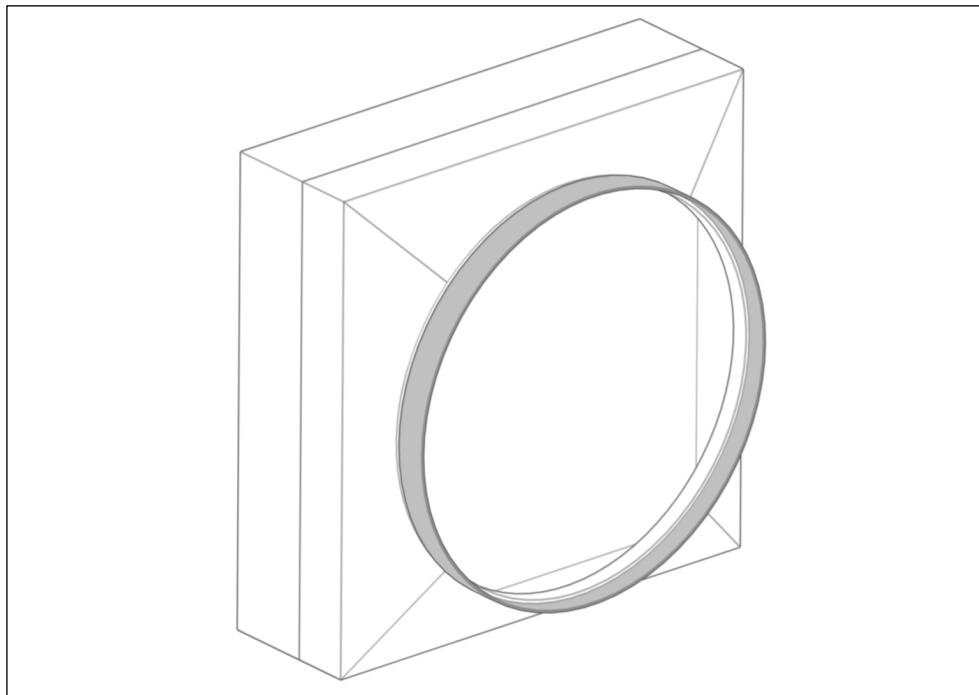

Fig. 13

5.2 Installing the pressure hose

NOTE

A bent air intake tube may cause damage!

The air intake tube may become bent when the pressure hose is installed. As a result, the pressure hose may collide with the fan blades and damage the fan.

- ▶ Carefully bend the air intake tube manually back into a horizontal position.

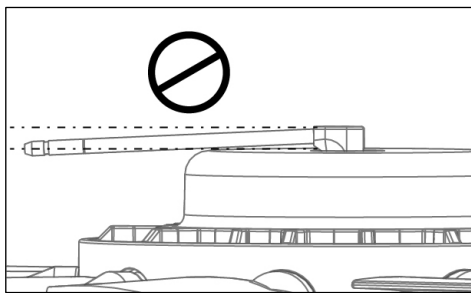

Fig. 14

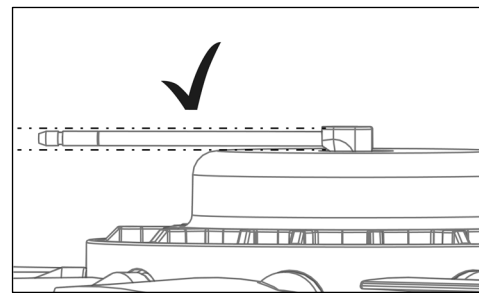

Fig. 15

An incorrectly installed hose clamp may cause damage!

When the hose clamp is installed, the ears might be positioned vertically. As a result, the ears might collide with the fan blades.

- ▶ Use hose clamp pincers to rotate the hose clamp until the ears are positioned horizontally.

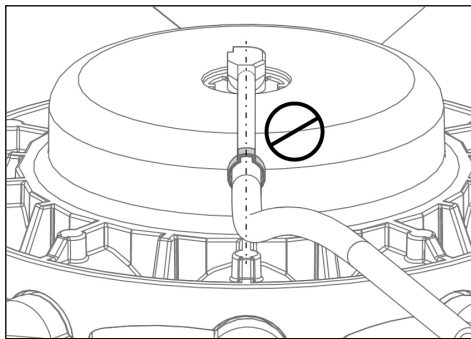

Fig. 16

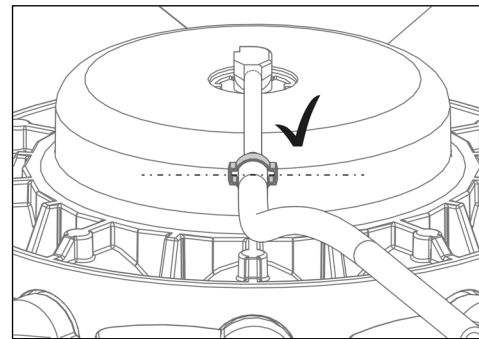

Fig. 17

- 7) Slide the hose clamp over the pressure hose.
- 8) Place a drop of oil at the opening of the air intake tube.
- 9) Slide the pressure hose over the air intake tube up to the mark (25 mm / 0.984") (Fig. 18).
- 10) Position the hose clamp as shown in Fig. 17.
- 11) Pinch the ears of the hose clamp together using hose clamp pincers.

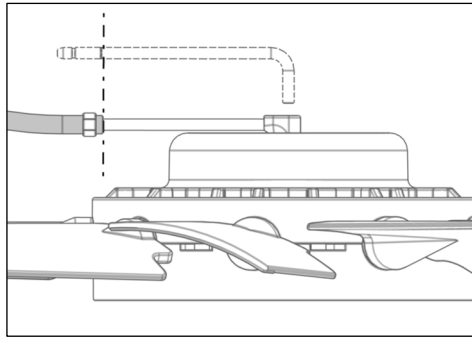

Fig. 18

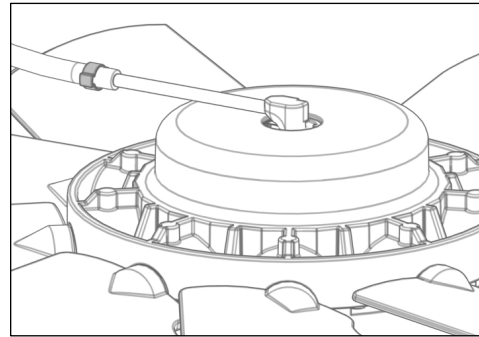

Fig. 19

5.3 Installing the flange

- 12) Remove all rust from the mounting surface to the machine.
- 13) Remove any remaining dirt.
- 14) Pull the label off the flange and clean the surface.
- 15) Attach the flange using screws (observe the machine manufacturer's indicated torque values).

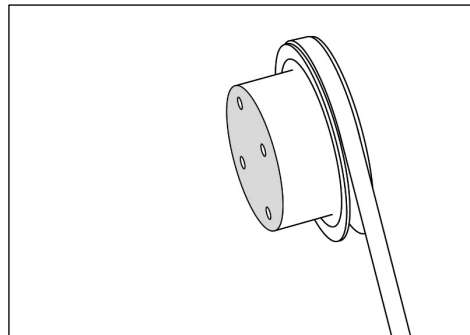

Fig. 20

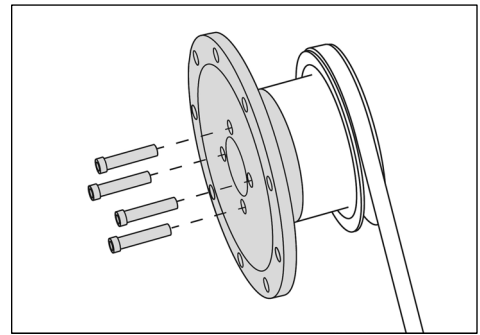

Fig. 21



When the flange is installed, the space needed to install the fan may become tight.

If this is the case:

- ▶ Use cardboard to protect the radiator fins.
- ▶ Guide the fan into the shroud.
- ▶ Install the flange.

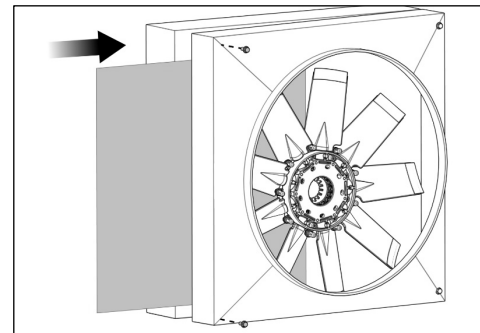

Fig. 22

NOTE

Using screws of the wrong length may cause damage!

If the screws are too short, the flange with the fan may come loose during operation.

Screws that are too long may cause damage to the machine.

- ▶ Check the length of the screws.
- ▶ If necessary, replace the screws.

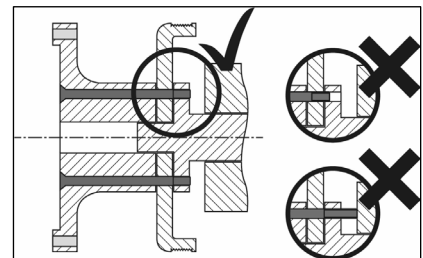

Fig. 23

5.4 Measuring the axial and radial runout

NOTE

Axial and radial runout may cause damage!

Imbalance damages the fan and the machine.

- ▶ The axial and radial runout must be checked using a dial gauge.
- ▶ If necessary, inspect the contact surfaces and clean them again.
- ▶ If necessary, rotate the flange to the next hole and repeat the process.

- 16) If necessary, reduce the belt tension to ensure exact measurement.
- 17) Check the axial and radial runout using a dial gauge.
- 18) The tolerance must not exceed 0.1 mm (0.004").

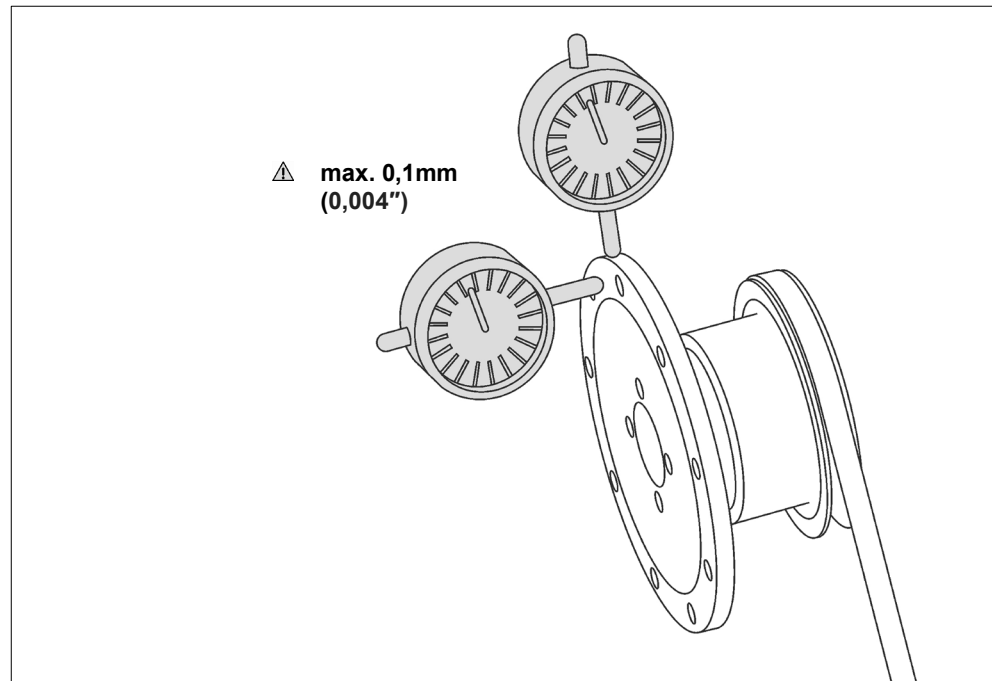

Fig. 24

5.5 Installing the fan



Installation depth

For the fan to reach its maximum airflow rate, it must be installed to an installation depth of $\frac{2}{3}$ of the blade profile in the shroud.

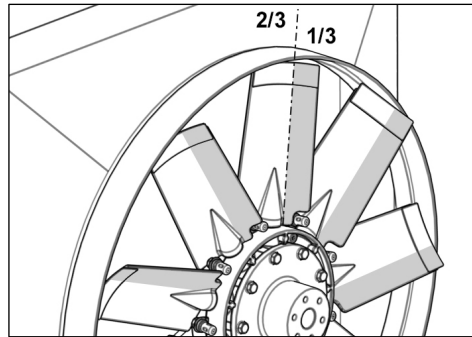

Fig. 25

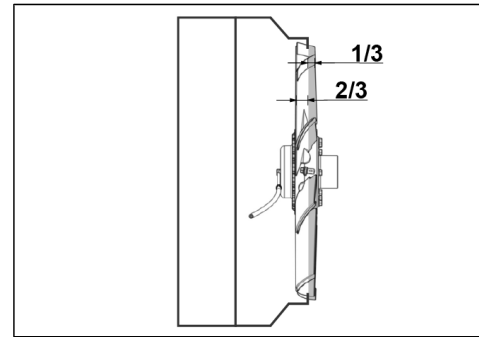

Fig. 26

Optional: Flex-Tips (blade extensions)

To increase the airflow rate, use elastic Flex-Tips to minimize the gap between the blade and the shroud.

Ideal airflow rate is achieved when the gap between the Flex-Tips and the shroud is 1 mm / 0.004". Out-of-roundness of the shroud may cause abrasion of material from the Flex-Tips due to contact with the shroud.

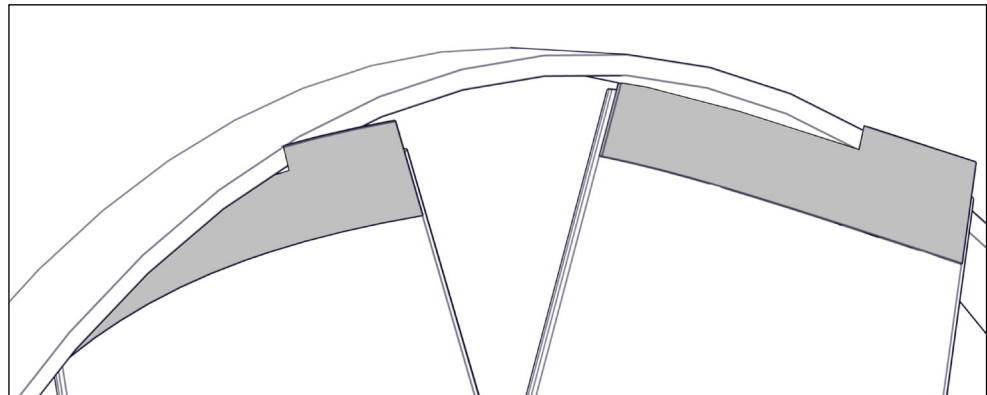

Fig. 27

NOTE

Careless installation of the fan may cause damage!

The radiator fins can be damaged if the fan is installed carelessly. This may reduce radiator performance.

- ▶ Use cardboard to protect the radiator fins.

19) Carefully guide the fan into the shroud.

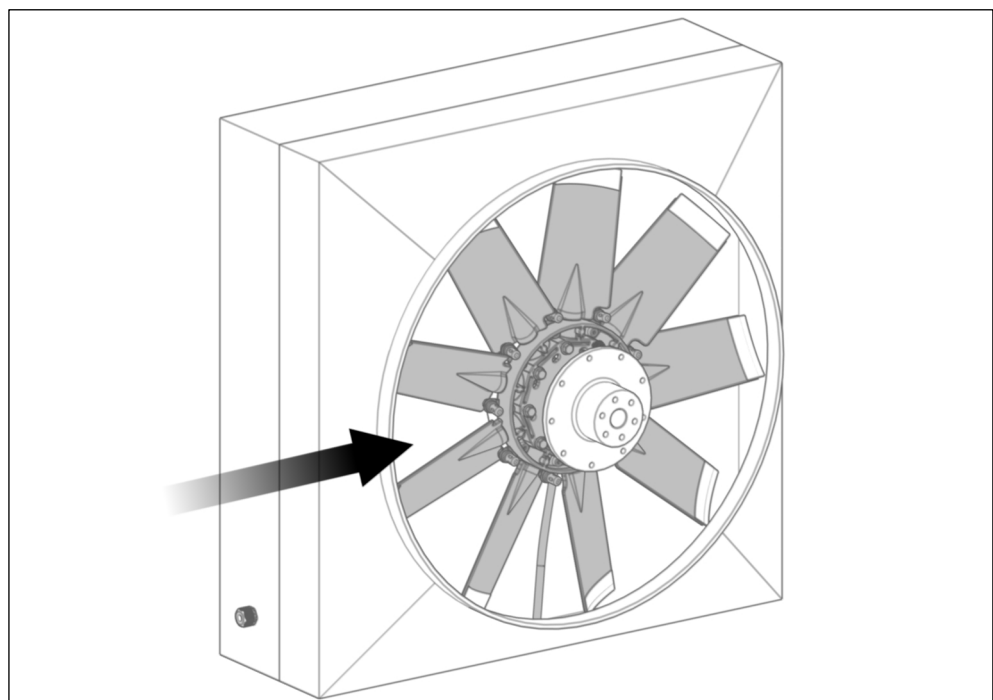

Fig. 28

- 20) Guide the pressure hose through the strain relief (see Fig. 29 step 1).
- 21) Set the fan on the flange.
- 22) Screw in the supplied mounting screws by hand (see Fig. 29 step 2).

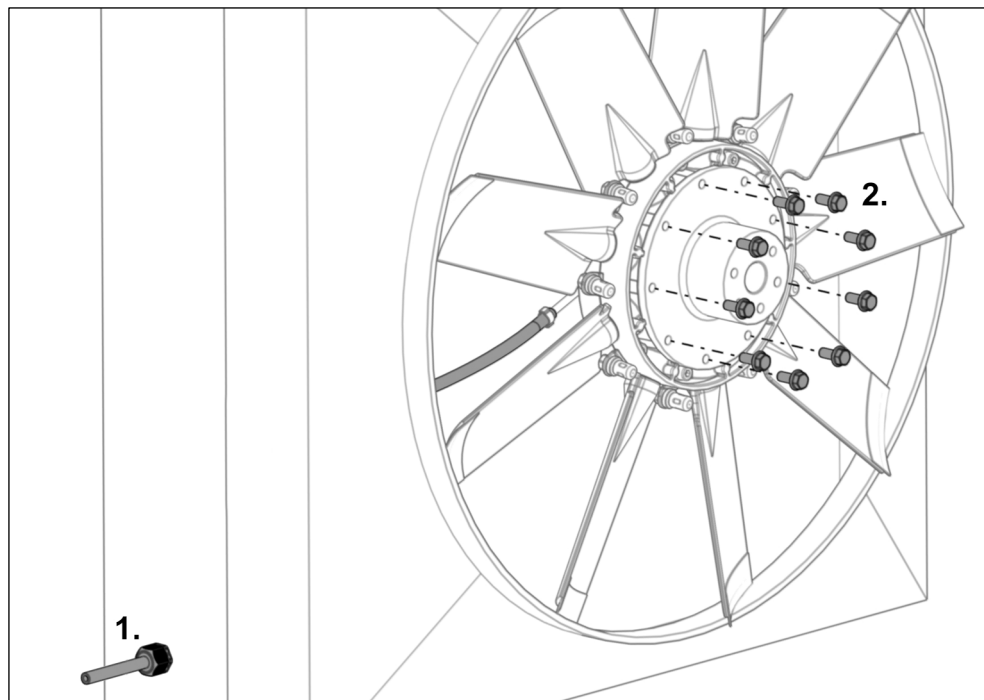

Fig. 29

- 23) Tighten the mounting screws to the specified torque.



Torque

C162, H162, C225 → 12 Nm

C200, C220, C222, H222, C252, H252, C300 → 20 Nm

5.6 Tensioning the pressure hose

NOTE

Incorrect tension of the pressure hose may cause damage!

If the tension is too low, the pressure hose may be caught by the fan blades during operation.

If the tension is too high, the seal at the air intake assembly may wear, causing the fan to leak air.

- ▶ Check the tension and, if necessary, retension the pressure hose (see Fig. 30).

- 24) Tension the pressure hose (see Fig. 31 step 1) so that the air intake assembly can rotate slightly (max. 15°).
- 25) Secure the pressure hose using the strain relief (see Fig. 31 step 2).

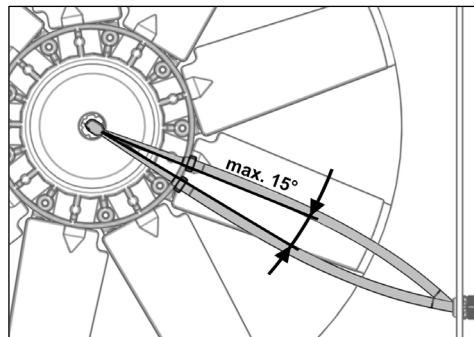

Fig. 30

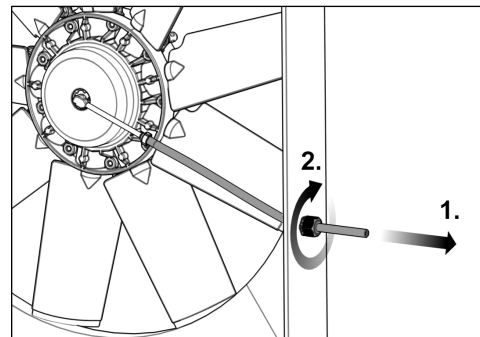

Fig. 31



For fans larger than 900 mm (35.433"), the pressure hose must be secured at mid-length.

5.7 Precluding collision

5.7.1 Pneumatic fan

- 26) Apply compressed air (max. 10 bar / 145 psi) to the fan until the fan blades are positioned crosswise.

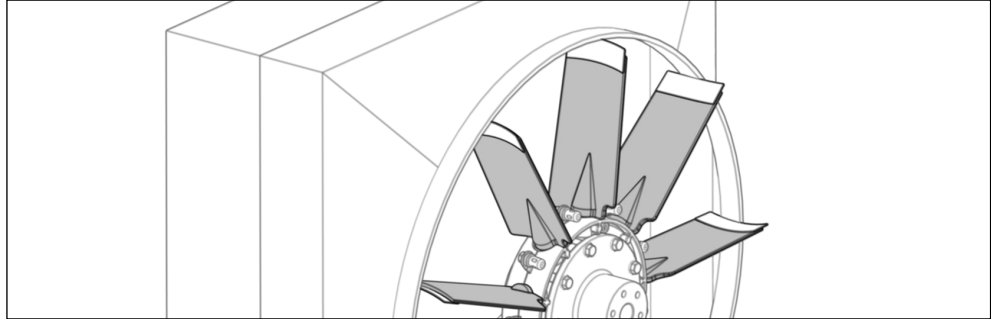

Fig. 32

- 27) Pinch the pressure hose (e.g., using locking pliers).
- 28) If necessary, reduce the belt tension.
- 29) Manually rotate the fan (see Fig. 33).
- 30) Make sure that when the blades are in the cross position, they do not collide with any objects in front of or behind the fan (minimum gap 5 mm (0.196") / see Fig. 34).
- 31) Make adjustments as needed.

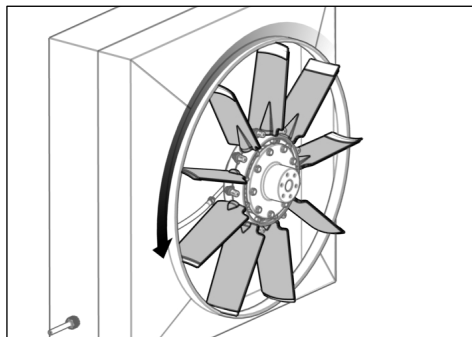

Fig. 33

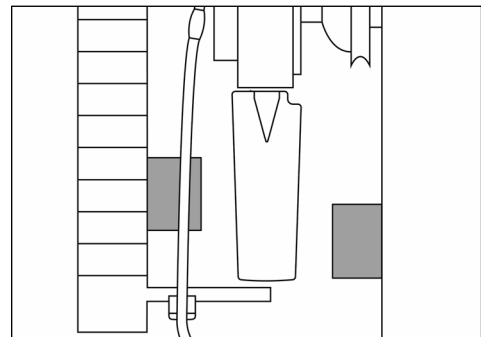

Fig. 34

- 32) Release the compressed air from the fan.

5.7.2 Hydraulic fan

You must ensure that the blades do not collide with any objects in front of or behind the fan when they are in the cross position. For hydraulic fans, you must do this through measurement because the fan cannot be reversed when the machine is stationary (hydraulic pressure is not available in the system).

Cooling position

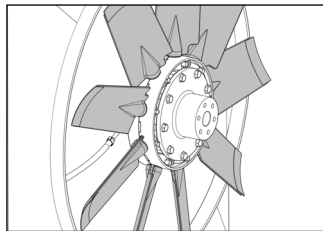

Fig. 35

Cross position

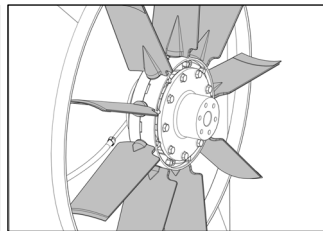

Fig. 36

Cleaning position

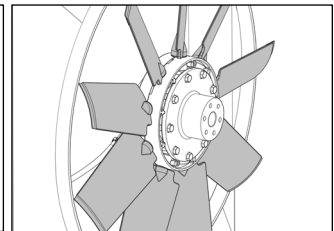

Fig. 37

33) Measure whether any objects are in the way (see Fig. 38).

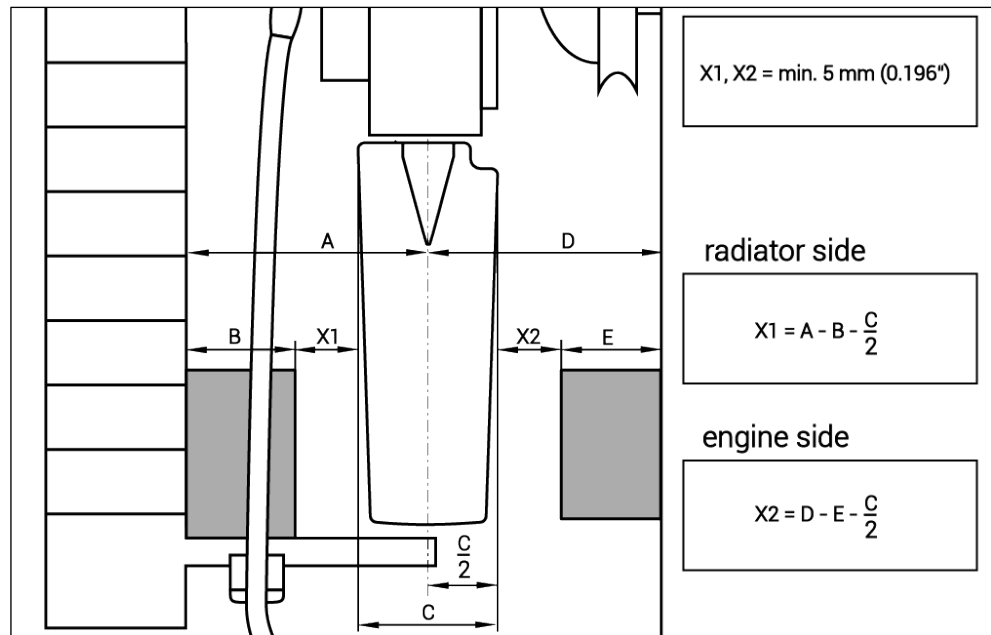

Fig. 38

- A = distance from the center of the blade to the radiator
- B = interfering contour on the radiator side
- C = blade width
- D = distance from the center of the blade to the engine
- E = interfering contour on the engine side
- X1, X2 = gap, min. 5 mm (0.196")

5.8 Installing the fitting on the pressure hose (H162)

- 34) Screw the sleeve counterclockwise onto the pressure hose until it stops (12 mm wrench).

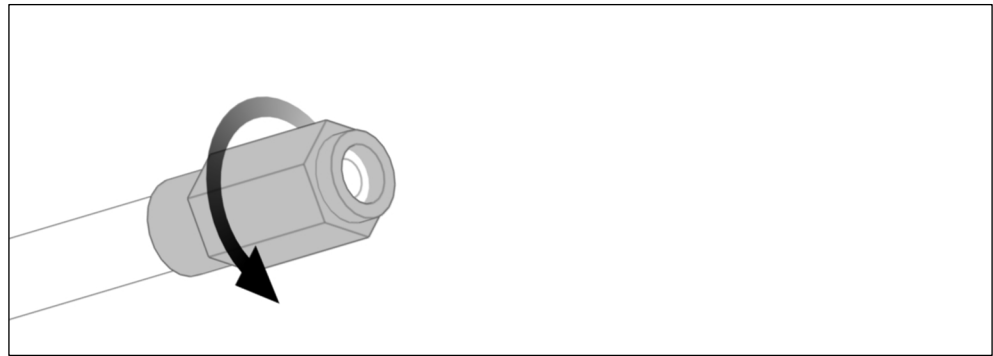

Fig. 39

- 35) Screw the connecting piece clockwise into the sleeve until it stops (10 mm wrench).

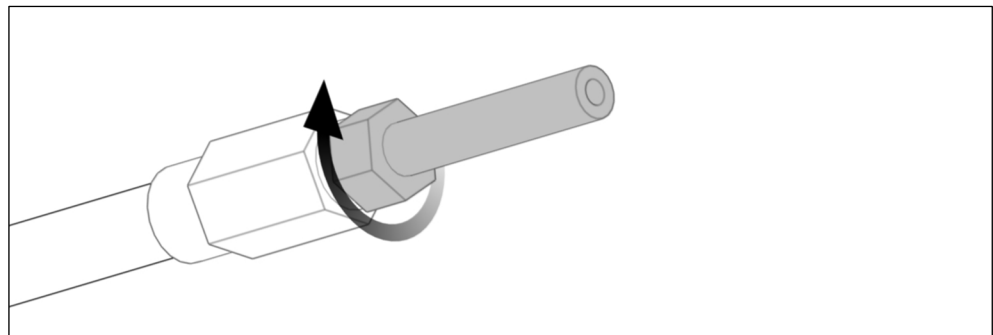

Fig. 40

6 Installing the electronics

NOTE

Using an incorrect power supply may cause damage!

Electronic components may be damaged when connected to an incorrect power supply.

- ▶ Make sure that electronic components are suitable for the existing voltage source (12 V / 24 V).

Environmental damage!

Electronic components may be damaged by environmental impacts.

- ▶ Install electronic components at a location that is protected from water, dust, vibrations, and heat (max. 70°C / 158°F).
- ▶ To ensure greater protection, you can install the air filter in the machine cab via an extension (see Fig. 82)

6.1 Installing electronic components

NOTE

Incorrect orientation of the air filter may cause damage!

Electronic components equipped with an air filter may be damaged by water entering the air filter.

- ▶ Install electronic components with the air filter oriented upward or to the side.

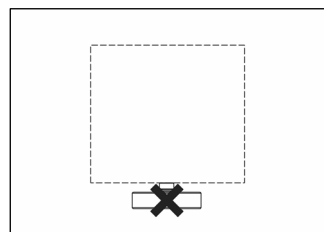

Fig. 41

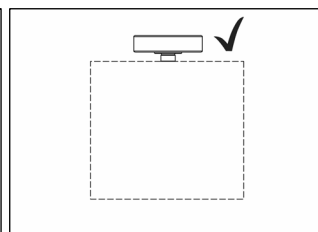

Fig. 42

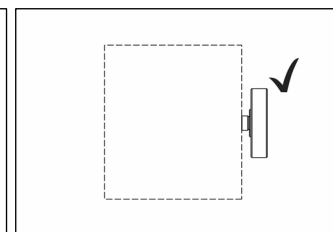

Fig. 43

- 36) Install the electronic component using suitable screws.

6.1.1 Installation dimensions

Pneumatic | Valve

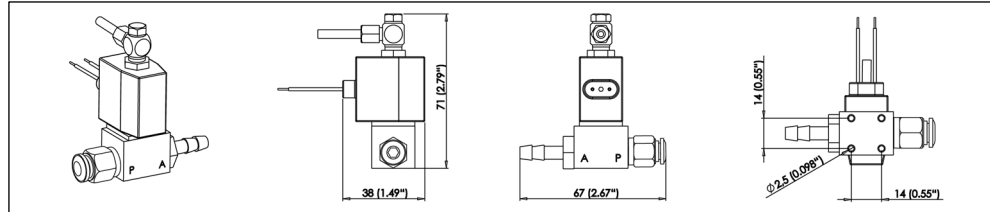

Fig. 44

Pneumatic | Valve unit

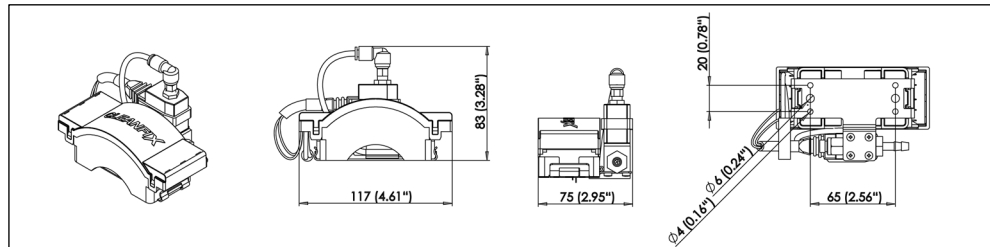

Fig. 45

Pneumatic | Control unit

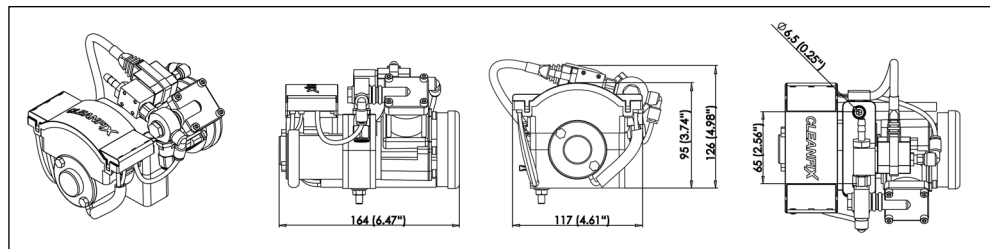

Fig. 46

Pneumatic | E-Box

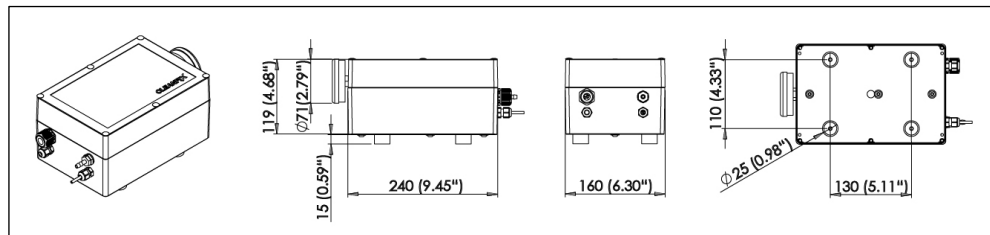

Fig. 47

Hydraulic | Valve

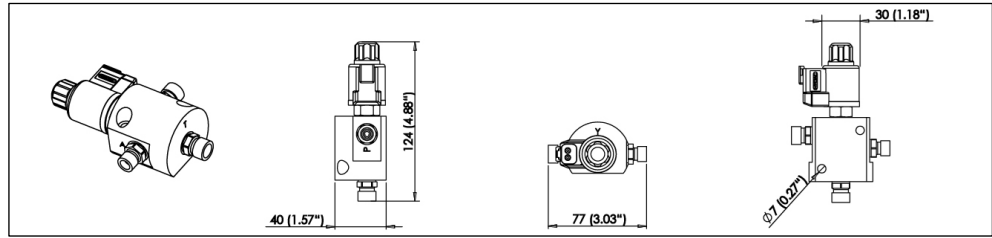

Fig. 48

Hydraulic | Valve unit

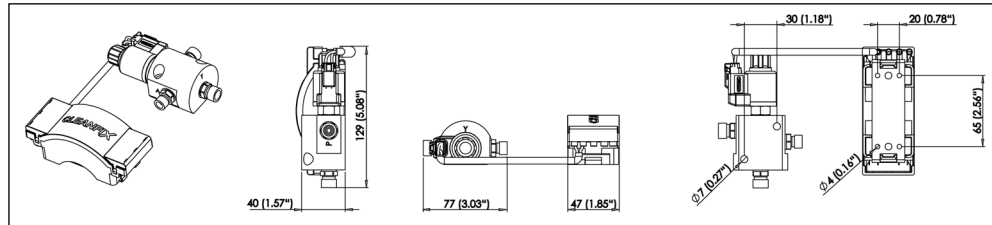

Fig. 49

Hydraulic | Combi block - Valve

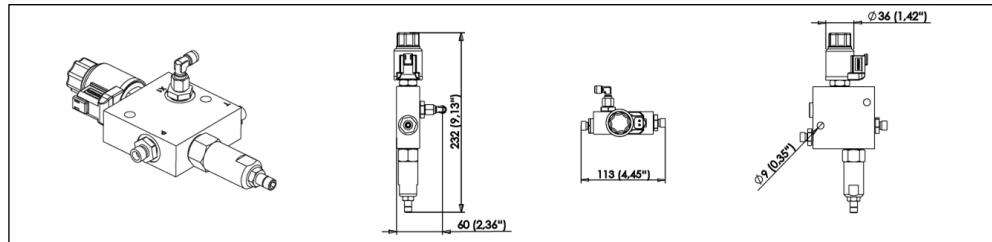

Fig. 50

Hydraulic | Combi block - Valve unit

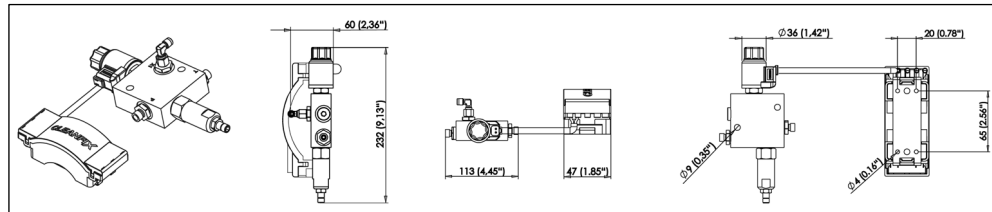

Fig. 51

6.1.2 Installation overview

Pneumatic | Valve

(for machines with a compressed air system)

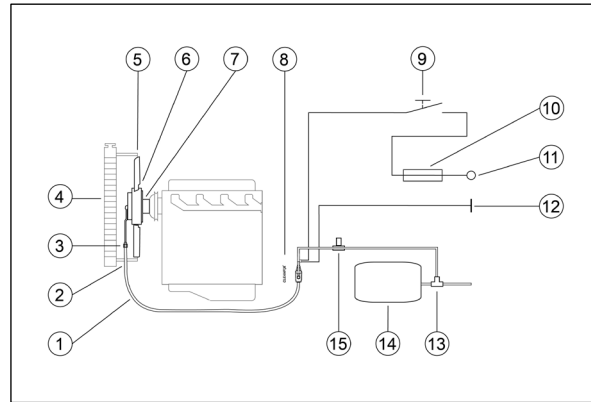

Fig. 52

- (1) Pressure hose
- (2) Hose screw connection
- (3) Hose clamp
- (4) Radiator
- (5) Shroud
- (6) Fan
- (7) Flange
- (8) Valve
- (9) Switch (push button)
- (10) Fuse (12 V : 20 A / 24 V : 15 A)
- (11) Keyed power (terminal 15) [red cable]
- (12) Machine ground (terminal 31) [black cable]
- (13) Tee
- (14) Compressed air reservoir
- (15) Overflow valve

Pneumatic | Valve unit

(for machines with a compressed air system)

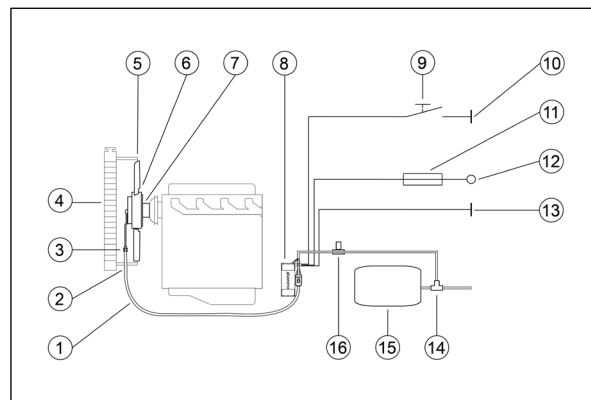

Fig. 53

- (1) Pressure hose
- (2) Hose screw connection
- (3) Hose clamp
- (4) Radiator
- (5) Shroud
- (6) Fan
- (7) Flange
- (8) Valve unit with Mini-Timer or Multi-Timer
- (9) Switch (push button)
- (10) Machine ground (terminal 31) [grey cable]
- (11) Fuse (12 V / 24 V : 3 A)
- (12) Keyed power (terminal 15) [red cable]
- (13) Machine ground (terminal 31) [black cable]
- (14) Tee
- (15) Compressed air reservoir
- (16) Overflow valve

Pneumatic | Control unit

(for machines without a compressed air system)

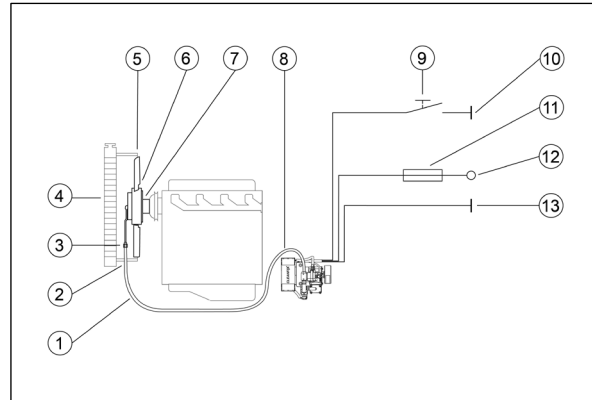

Fig. 54

- (1) Pressure hose
- (2) Hose screw connection
- (3) Hose clamp
- (4) Radiator
- (5) Shroud
- (6) Fan
- (7) Flange
- (8) Control unit with Mini-Timer or Multi-Timer
- (9) Switch (push button)
- (10) Machine ground (terminal 31) [grey cable]
- (11) Fuse (12 V : 20 A / 24 V : 15 A)
- (12) Keyed power (terminal 15) [red cable]
- (13) Machine ground (terminal 31) [black cable]

Pneumatic | E-Box

(for machines without a compressed air system)

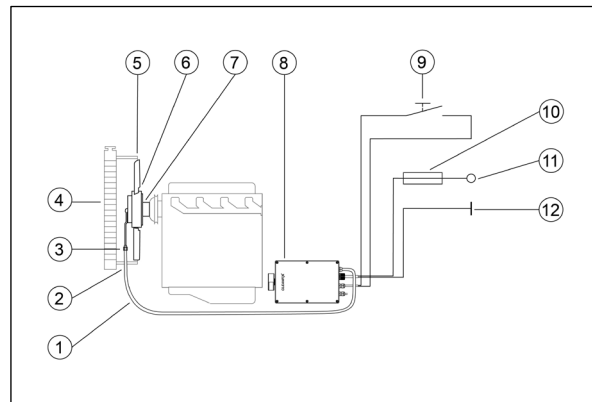

Fig. 55

- (1) Pressure hose
- (2) Hose screw connection
- (3) Hose clamp
- (4) Radiator
- (5) Shroud
- (6) Fan
- (7) Flange
- (8) E-Box with Multi-Timer
- (9) Switch (push button)
- (10) Fuse (12 V : 20 A / 24 V : 15 A)
- (11) Keyed power (terminal 15) [red cable]
- (12) Machine ground (terminal 31) [black cable]

Hydraulic | Valve

(for machines with a hydraulic system)

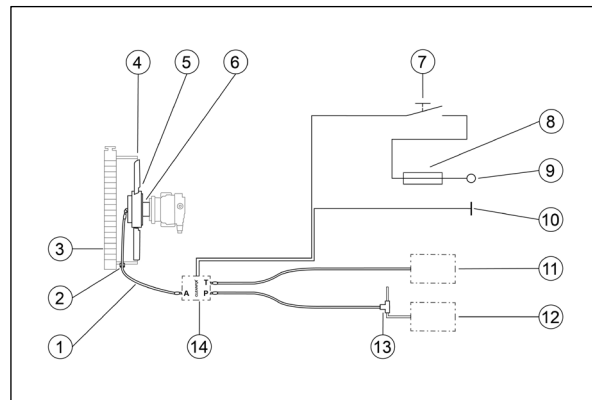

Fig. 56

- (1) Hose connection between the fan and valve
- (2) Hose screw connection
- (3) Radiator
- (4) Shroud
- (5) Fan
- (6) Flange
- (7) Switch (push button)
- (8) Fuse (12 V / 24 V : 3 A)
- (9) Keyed power (terminal 15) [red cable]
- (10) Machine ground (terminal 31) [black cable]
- (11) Hydraulic oil reservoir
- (12) Hydro pump
- (13) Tee
- (14) Valve

Hydraulic | Valve unit

(for machines with a hydraulic system)

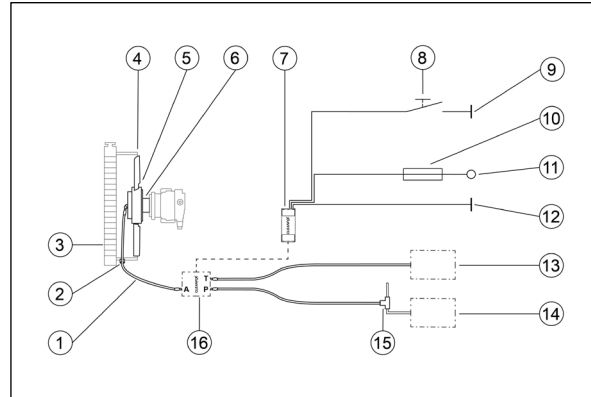

Fig. 57

- (1) Hose connection between the fan and valve
- (2) Hose screw connection
- (3) Radiator
- (4) Shroud
- (5) Fan
- (6) Flange
- (7) Timer control
- (8) Switch (push button)
- (9) Machine ground (terminal 31) [grey cable]
- (10) Fuse (12 V / 24 V : 3 A)
- (11) Keyed power (terminal 15) [red cable]
- (12) Machine ground (terminal 31) [black cable]
- (13) Hydraulic oil reservoir
- (14) Hydro pump
- (15) Tee
- (16) Valve

Hydraulic | Combi block - Valve

(for machines with a hydraulic system)

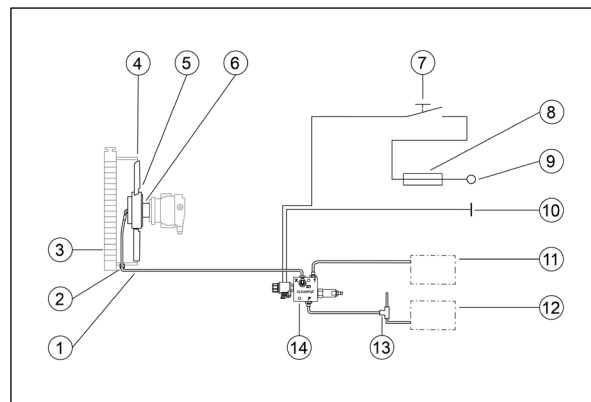

Fig. 58

- (1) Hose connection between the fan and valve
- (2) Hose screw connection
- (3) Radiator
- (4) Shroud
- (5) Fan
- (6) Flange
- (7) Switch (push button)
- (8) Fuse (12 V / 24 V : 3 A)
- (9) Keyed power (terminal 15) [red cable]
- (10) Machine ground (terminal 31) [black cable]
- (11) Hydraulic oil reservoir
- (12) Hydro pump
- (13) Tee
- (14) Combi block - Pressure reducing 3/2 way valve

Hydraulic | Combi block - Valve unit

(for machines with a hydraulic system)

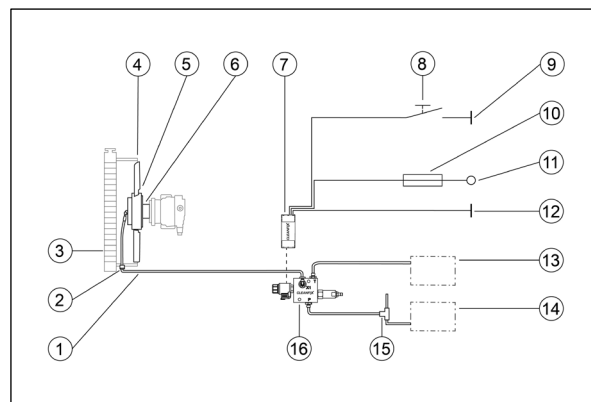

Fig. 59

- (1) Hose connection between the fan and valve
- (2) Hose screw connection
- (3) Radiator
- (4) Shroud
- (5) Fan
- (6) Flange
- (7) Timer control
- (8) Switch (push button)
- (9) Machine ground (terminal 31) [grey cable]
- (10) Fuse (12 V / 24 V : 3 A)
- (11) Keyed power (terminal 15) [red cable]
- (12) Machine ground (terminal 31) [black cable]
- (13) Hydraulic oil reservoir
- (14) Hydro pump
- (15) Tee
- (16) Combi block - Pressure reducing 3/2 way valve

6.2 Installing the push button (optional)

The fan is reversed via the push button and/or the Cleanfix control app (see chapter 11). If fan reversal is to be controlled exclusively via the Cleanfix control app, it is not necessary to install the push button.



Installation location

If a free space is available for the push button in the consoles, this space can be used. Otherwise, a hole must be drilled in the console for the supplied push button.

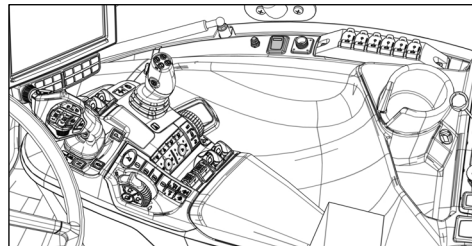

Fig. 60

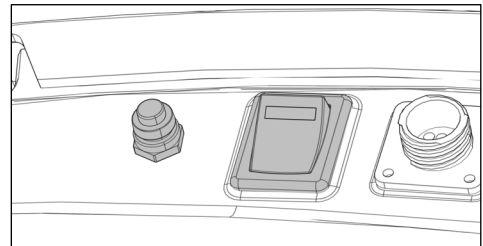

Fig. 61

- 37) Determine the installation location for the push button.

NOTE

Drilling into electronic components may cause damage!

Electronic components are installed under the consoles. These components can be damaged during drilling.

- ▶ Check whether electronic components are in the way.
- ▶ Drill carefully.

- 38) If necessary, drill a hole (22 mm / 0.866") in the console.
- 39) Install the push button.

6.3 Connecting the electronic component to the power supply



Power supply

If a switched, fused power supply (terminal 15) with sufficient voltage (see Fig. 62 - Fig. 69) is available, it can be used.

- 40) Connect the electronic component to the machine's power supply (see Fig. 62 - Fig. 69).

Pneumatic | Valve

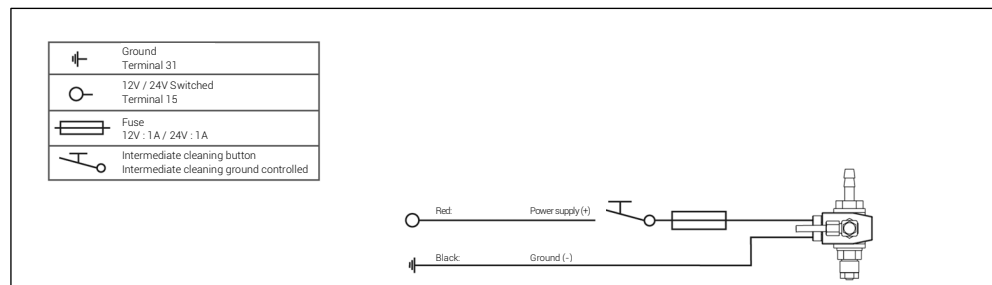

Fig. 62

Pneumatic | Valve unit

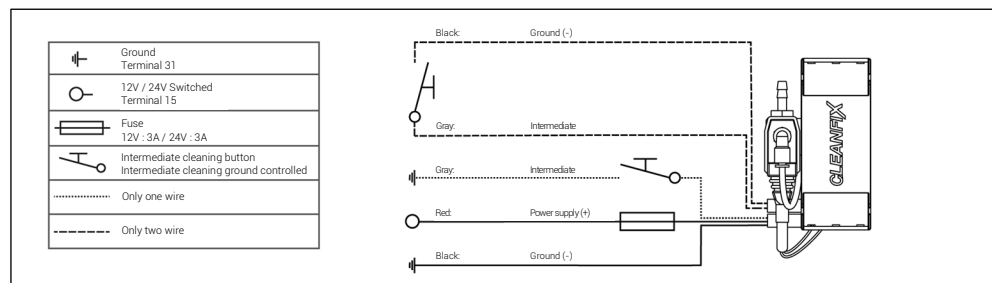

Fig. 63

Pneumatic | Control unit

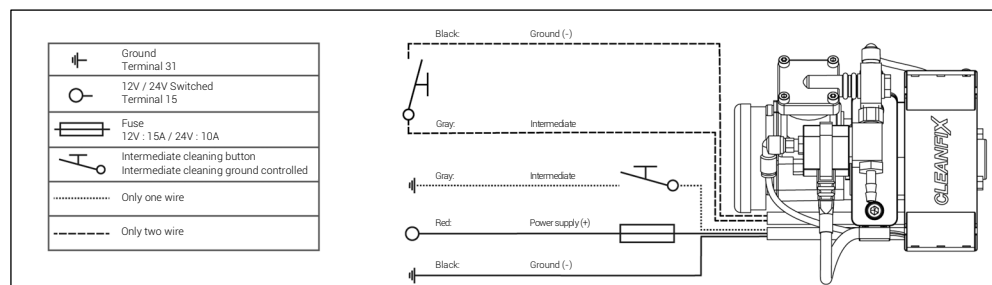

Fig. 64

Pneumatic | E-Box

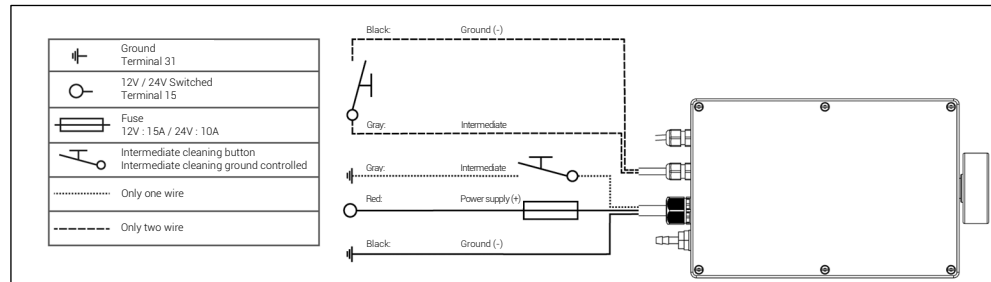

Fig. 65

Hydraulic | Valve

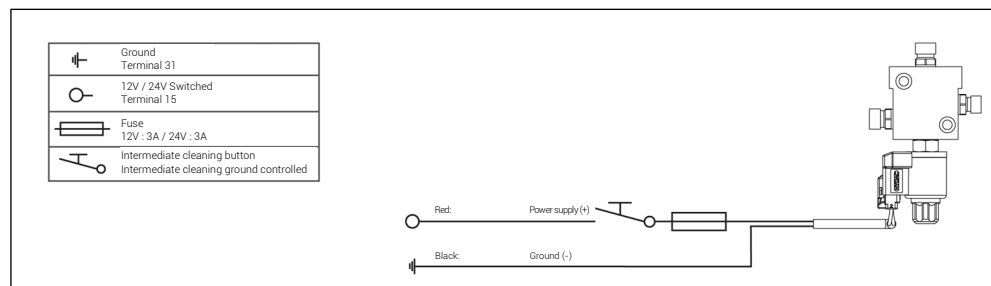

Fig. 66

Hydraulic | Valve unit

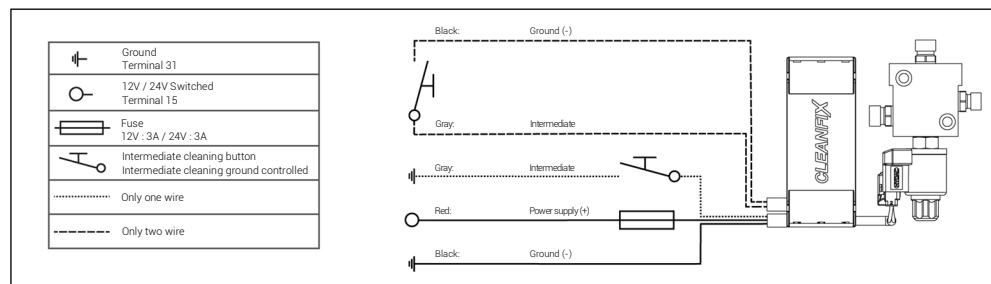

Fig. 67

Hydraulic | Combi block - Valve

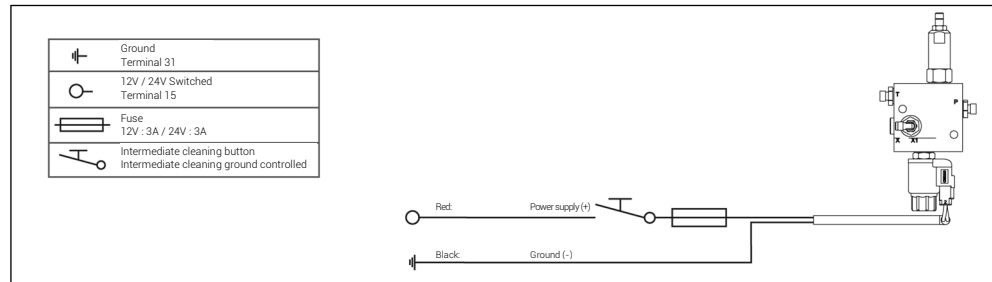

Fig. 68

Hydraulic | Combi block - Valve unit

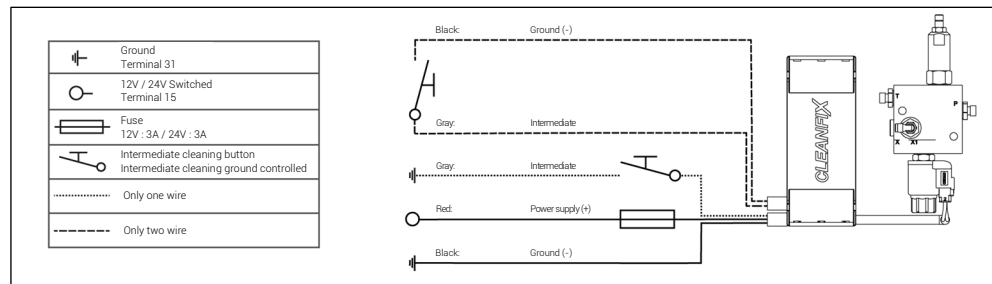

Fig. 69

7 Installing the pressure hose (pneumatic fans)

7.1 Connecting the electronic component to the fan

- 41) Cut the pressure hose to a suitable length.
- 42) Place a drop of oil at the opening of the pressure hose.
- 43) Slide the hose clamp over the pressure hose.
- 44) Slide the pressure hose over the hose fitting (A) of the electronic component.
- 45) Pinch the ears of the hose clamp together using hose clamp pincers.

7.2 Connecting the electronic component to the compressed air system



Electronic component connection to the compressed air system

If the compressed air system has an auxiliary consumer circuit (fused compressed air circuit), this circuit can be used.

If an auxiliary consumer circuit is not available, an appropriate overflow valve must be installed between the electronic component and the compressed air system.

Overflow valve kit

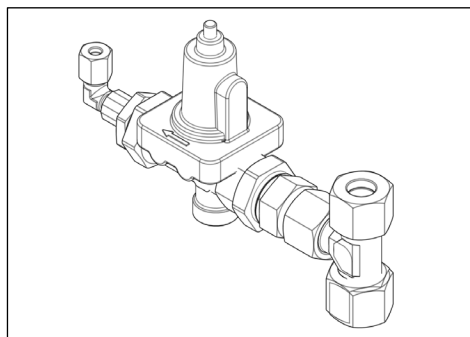

Fig. 70

Item no.: 216205

- 46) Connect the electronic component to the compressed air system.

8 Installing the pressure hose (hydraulic fans)

8.1 Connecting the electronic component to the fan

NOTE

Lengthening the pressure hose may cause damage to the fan!

If the pressure hose is lengthened, the exchange of hydraulic oil within the fan is not guaranteed.

- ▶ The supplied pressure hose must not be lengthened and must be connected directly to the electronic component.

47) Connect the pressure hose to connector (A) of the electronic component.

8.2 Connecting the electronic component to the hydraulic system

NOTE

Excessive pressure on the seals and hub may cause damage!

Excessive pressure at the pressure supply may cause damage to the seals and hub (risk of bursting).

- ▶ The pressure supply must not exceed 50 bar / 725.19 psi.



Hose connection return flow: nominal size min. DN 8

48) Use suitable pressure hose to connect the electronic component to the hydraulic system.

9 Initial start-up

 WARNING!

Flying parts may result in serious injury or death!

Loose parts can be drawn in by the fan and may cause serious injury or death as well as machine damage.

- ▶ Remove tools and loose objects.
 - ▶ Reliably secure components near the fan.
-

- 49) Start the engine.
 - 50) Reverse the fan three times in neutral.
-



If Flex-Tips are used, slight abrasion of material will occur.

- 51) Reverse the fan once at approx. 1/3 of the max. rotational speed.
- 52) Reverse the fan once at approx. 2/3 of the max. rotational speed.
- 53) Reverse the fan once at full rotational speed.

10 Operation (push button)

⚠ CAUTION!

Flying dirt may cause injuries!

Persons near the radiator may be hit by flying dirt.

- ▶ Before activating the reversing function, make sure that nobody is in the vicinity of the radiator.
- ▶ Before activating the reversing function, make sure that the machine is not in a closed space.

NOTE

Reversing the fan while the machine is in the red temperature range may result in damage!

The cooling effect is interrupted when the reversing function is activated. Reversing the fan while the machine is in the red temperature range causes the engine to overheat.

- ▶ Do not reverse the fan when the machine is in the red temperature range.
- ▶ Park the machine and open the hood so that it can cool down.

Electronic component without timer (semi-automatic cleaning)

Press the push button to change from cooling to cleaning. The fan remains in cleaning mode for as long as the switch is pressed. The cooling effect is interrupted when the reversing function is activated. Do not hold the push button down too long (see table).

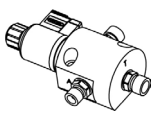
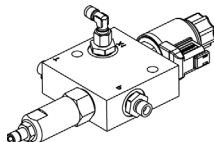
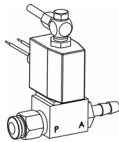
Hydraulic activation		Pneumatic activation
With a hydraulic system in the machine Hold the push button down for max. 15 sec.		With a compressed air system in the machine Hold the push button down for max. 15 sec.
Valve  Fig. 71	Combi block - Valve  Fig. 72	Valve  Fig. 73

Electronic component with timer (fully automatic cleaning at intervals)

Switching from cooling to cleaning and back is controlled by the set interval, for example, every 30 minutes. This time interval can be modified as desired via the Cleanfix control app (see chapter 11). Intermediate cleaning can be performed manually at any time by pressing the push button or via the Cleanfix control app. By default, the first cleaning operation will start immediately after the power supply is attached. The first cleaning operation can be started after a time delay in customized solutions.

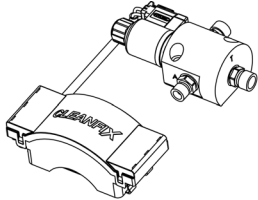
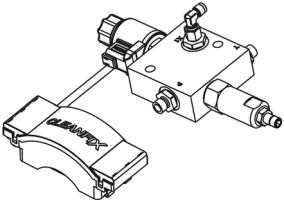
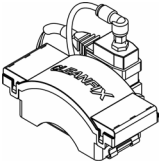
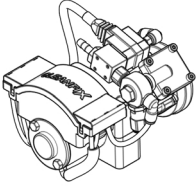
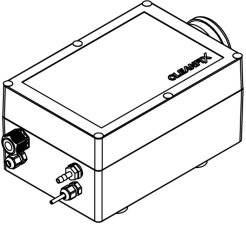
Hydraulic activation		Pneumatic activation	
With a hydraulic system in the machine		With a compressed air system in the machine	Without a compressed air system in the machine
Valve unit  Fig. 74	Combi block - Valve unit  Fig. 75	Valve unit  Fig. 76	Control unit  Fig. 77 E-Box  Fig. 78

11 Operation (Cleanfix control app)

WARNING!

Using the app while driving may cause major injuries or death!

Using the app in traffic on public roads impairs traffic safety.

- ▶ Do not use the app in traffic on public roads.
- ▶ Do not reverse the fan in traffic on public roads.

CAUTION!

Flying dirt may cause injuries!

Persons near the radiator may be hit by flying dirt.

- ▶ Before activating the reversing function, make sure that nobody is in the vicinity of the radiator.
- ▶ Before activating the reversing function, make sure that the machine is not in a closed space.

NOTE

Reversing the fan while the machine is in the red temperature range may result in damage!

The cooling effect is interrupted when the reversing function is activated.

Reversing the fan while the machine is in the red temperature range causes the engine to overheat.

- ▶ Do not reverse the fan when the machine is in the red temperature range.
- ▶ Park the machine and open the hood so that it can cool down.

Cleanfix offers an app that can be used to operate the electronic components with timer and to make settings.

The Cleanfix control app provides the following functions:

- Switching between automatic and manual operation
- Setting the cycle time
- Pausing cleaning
- Pairing with the device
- Monitoring the air filter status
- Performing manual cleaning
- Performing a system check

11.1 Downloading the app

- 54) Open the app store on your mobile device.
- 55) Search for Cleanfix control app in the app store.
- 56) Download the Cleanfix control app.
- 57) Open the Cleanfix control app.



Mobile device access

So that the app can access certain functions on your mobile device, you must accept the permissions.

The app requires Bluetooth access. Access might not be available in every country.

- 58) Follow the instructions on your mobile device.
- 59) If necessary, install the update.



Updates

To ensure that the app will function optimally and is the current version, install all updates.

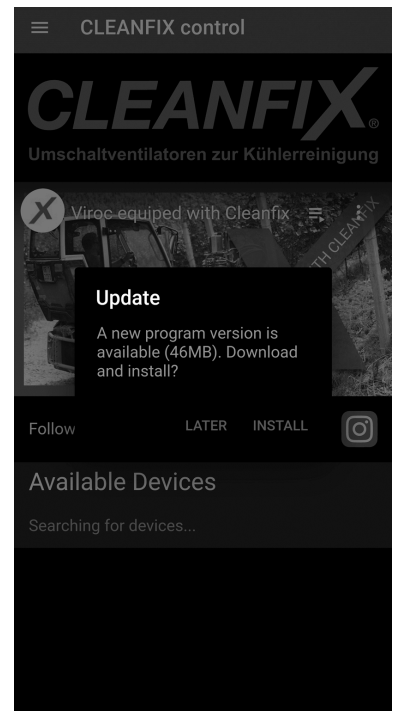

Fig. 79

11.2 Pairing the device

60) Tap the ☰ button to open the menu.

61) Select [Devices].

i For subsequent steps, the device must be turned on.

- ▶ If necessary, turn on the ignition.

62) Swipe downward to start the search for devices.

63) Select the relevant device.

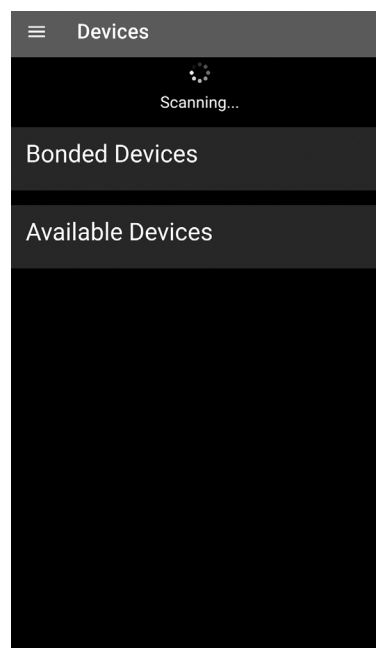
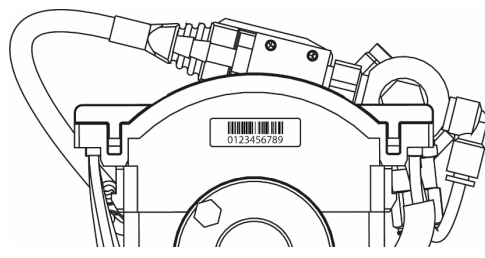

Fig. 80

64) Enter the PIN.

i The PIN consists of the last six digits of the device serial number.



65) Tap [Pairing] to confirm.

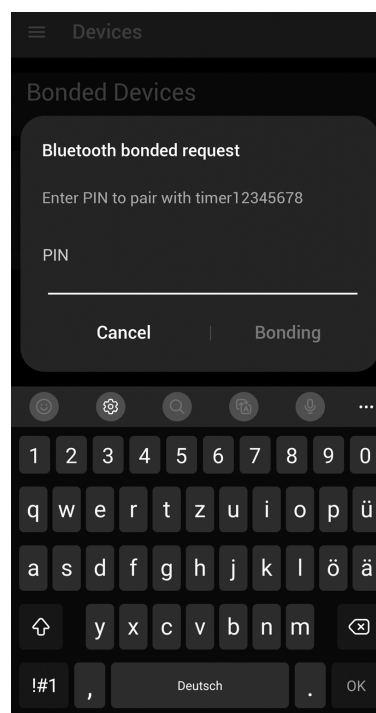

Fig. 81

- 66) Define the [device name].
- 67) Enter the average [altitude] of the working environment.
- 68) Tap [next] to confirm.

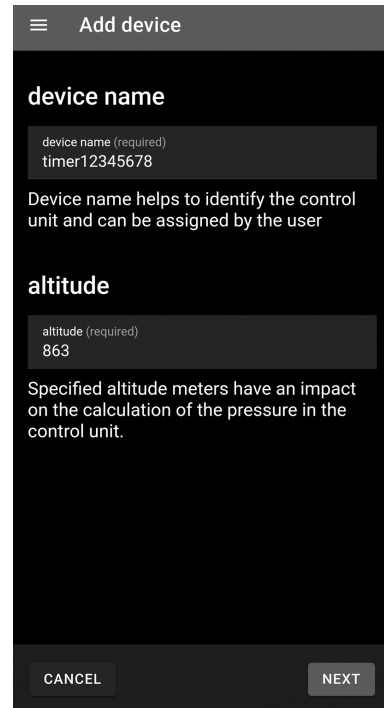

Fig. 82

- 69) Enter or scan the [serial number fan].
- 70) Tap [next] to confirm.

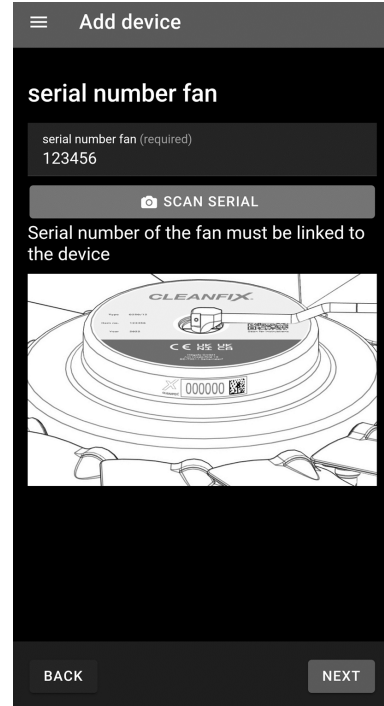

Fig. 83

- 71) Optionally, enter or scan the [serial number valve].
- 72) Tap [next] to confirm.

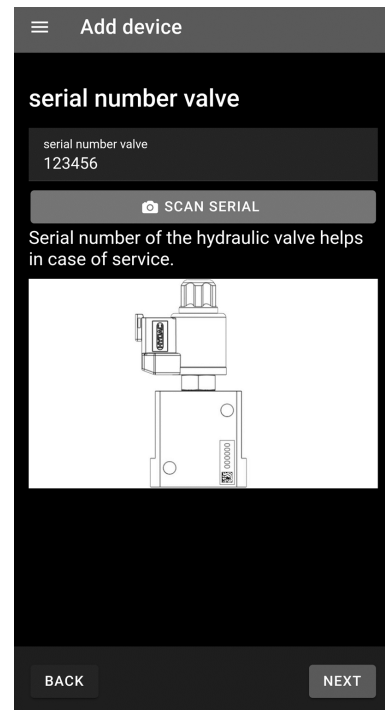

Fig. 84

- 73) Optionally, enter or scan the [serial number DSG].
- 74) Tap [save] to confirm.

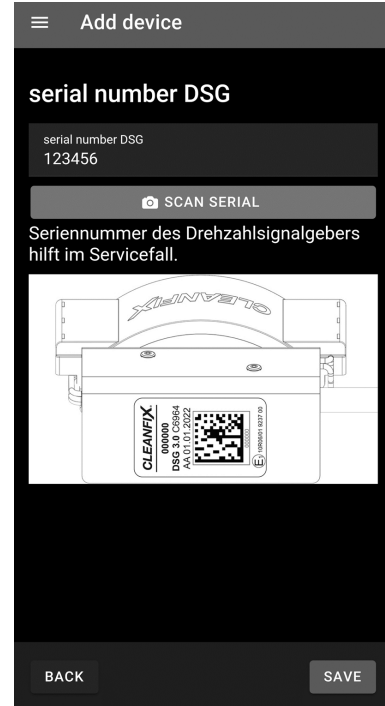

Fig. 85

11.3 Editing the device

- 75) Select the device from the [Devices] or the main screen.
- 76) Tap the ⚙️ button to open the [Edit Device] dialog.
- 77) Adapt the information accordingly.
- 78) Tap [save] to confirm.

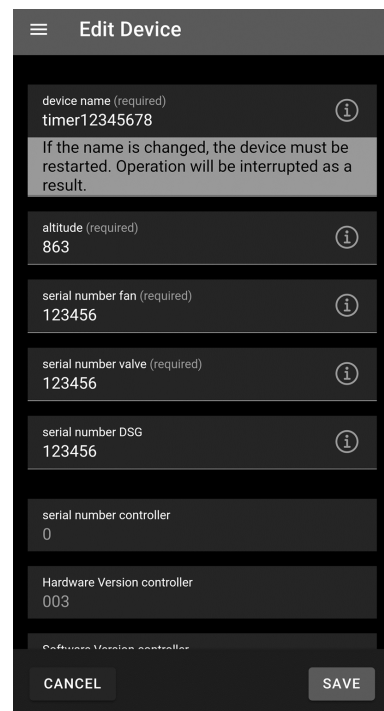

Fig. 86

11.4 Performing a system check

- 79) Select the device from the [Devices] or the main screen.
- 80) Tap the 🔍 button to open the [Check] dialog.
- 81) Tap the ▶️ button to start the system check.

i The system check is performed. The result is shown when the check is complete.

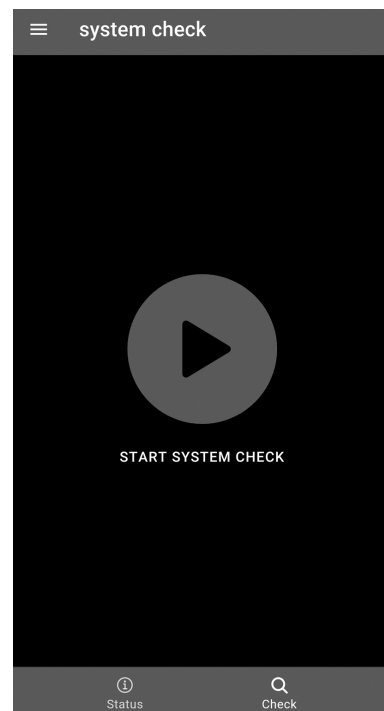



Fig. 87

A) System check successful

i Sharing the results

The result of the system check can be transmitted or saved as a PDF file via the [ share results] button.

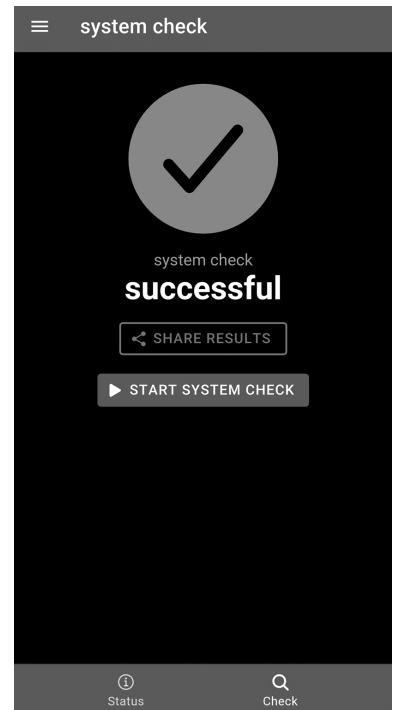



Fig. 88

B) System check failed

- Contact the dealer or manufacturer.

i Sharing the results

The result of the system check can be transmitted or saved as a PDF file via the [ share results] button.

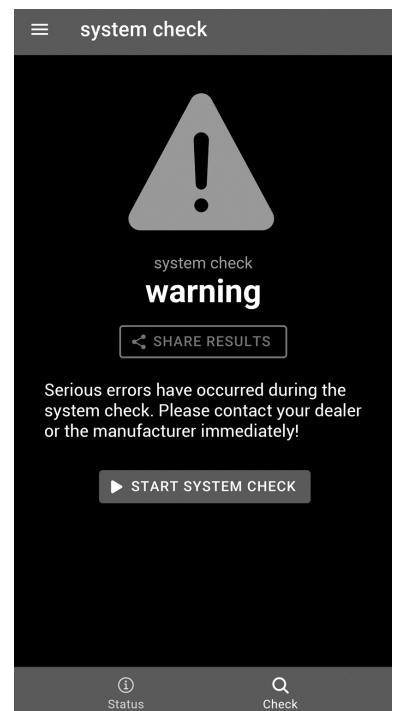

Fig. 89

11.5 Performing manual cleaning

- 82) Select the device from the [Devices] or the main screen.
- 83) Tap the [* manual cleaning] button to performing manual cleaning.

i If [* manual cleaning] is tapped during automatic operation, intermediate cleaning is performed. The cycle time then starts over.

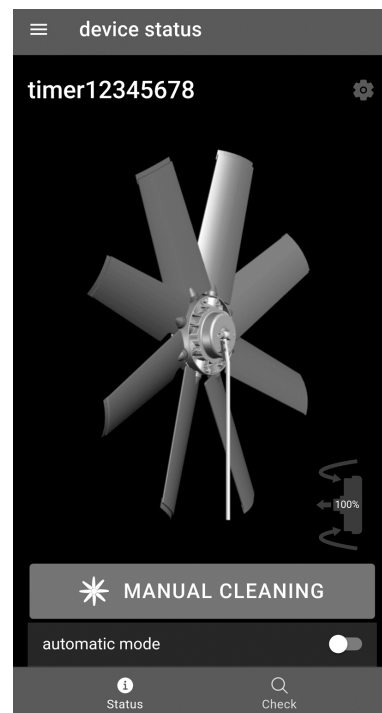

Fig. 90

11.6 Turning automatic operation on/off

- 84) Select the device from the [Devices] or the main screen.
- 85) In the [automatic mode] dialog, tap the switch to turn automatic operation on or off.
- 86) Select the [cycle time] dialog to set the cycle time.
- 87) Select a cycle time between 5 and 120 minutes.

i You can pause automatic operation by tapping the [|| pause] button and then resume automatic operation by tapping the [▶ resume] button.

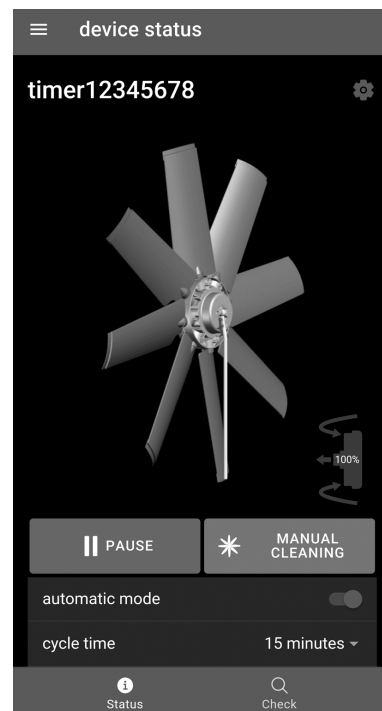

Fig. 91

11.7 Removing a device

- 88) Tap the ☰ button to open the menu.
- 89) Select the [Devices] menu screen.
- 90) Swipe the corresponding device to the left to display options.
- 91) Tap the 🗑 button to remove the device.

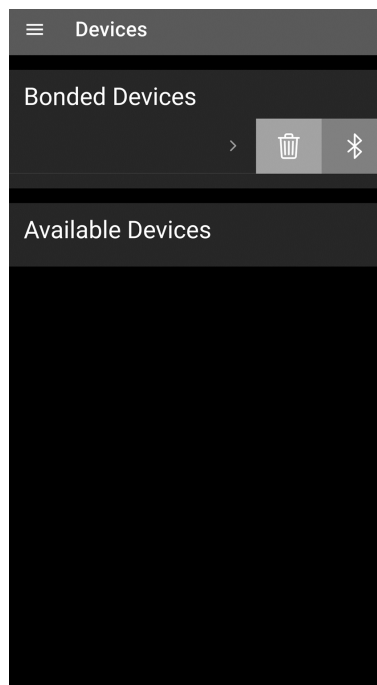

Fig. 92

11.8 Showing the air filter status

- i** The air filter on the device becomes clogged in the course of operation. This occurs depending on the operating time and the number of times the fan is reversed.

The indicator on the filter symbol shows the air filter status. If the value falls below 10%, a corresponding message appears and filter replacement is recommended (see section 12.2).

- 92) Select the device from the [Devices] or the main screen.
- 93) Tap the 🗑 button to show the air filter status.
- 94) Tap [OK] to confirm.

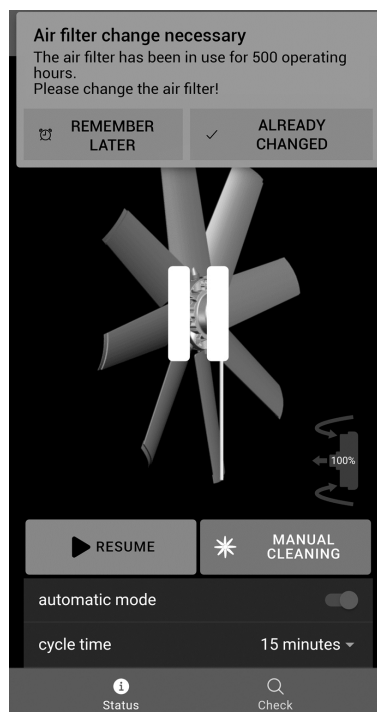

Fig. 93

12 Maintenance

12.1 Servicing the fan

The fan is maintenance-free.

In extreme operating conditions, a visual inspection of the moving parts is recommended at every maintenance interval of the machine.

12.2 Servicing the electronic components

For pneumatic electronic components with a compressor, the filter must be replaced at every maintenance interval of the machine, but at the least after 500 operating hours.

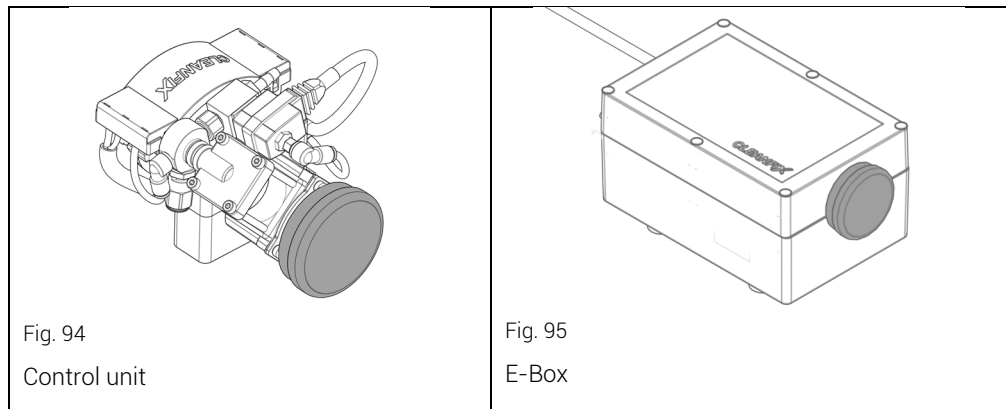

Filter replacement parts:

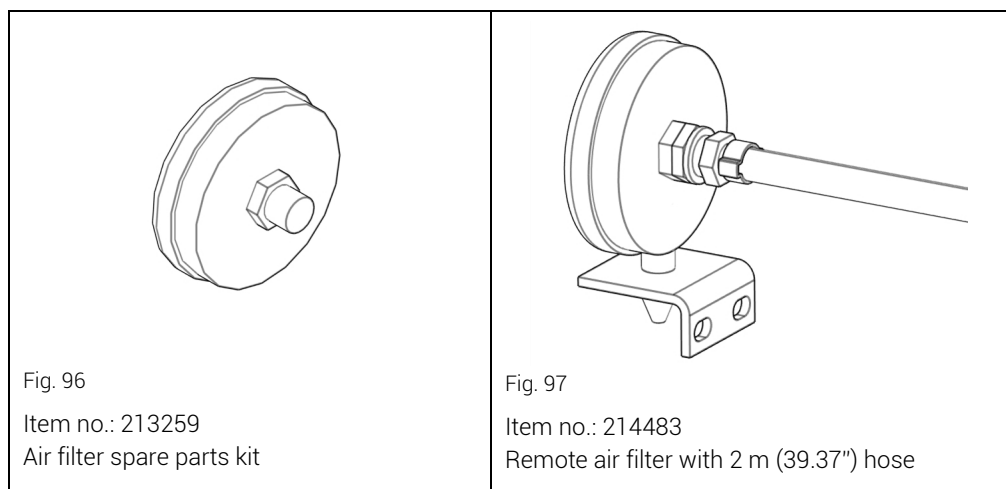

13 Troubleshooting (fans)

13.1 Blades do not rotate to the cleaning position

No or low pressure supply (for pneumatic or hydraulic system)

Check	Comment	Action
Check the pressure supply.	<p>Pneumatic system</p> <p>Pressure of min. 6.5 bar / 94.27 psi to max. 8 bar / 116.03 psi must be applied to the electronic component.</p> <p>Hydraulic system</p> <p>Pressure of min. 20 bar (H222, H252) or 42 bar (H162) must be applied to the electronic component.</p> <p>Max. 50 bar / 725.19 psi may be applied.</p>	Set the pressure supply.
Check the valve function.	<p>The valve must click softly when the power supply is switched on and off.</p> <p>If necessary, connect an external power supply.</p> <p>Note: observe voltage of 12 V/ 24 V.</p>	If the valve does not click, it must be replaced.
Check the pressure hose.	<p>Pneumatic system</p> <p>If necessary, pull the pressure hose from the valve and connect it to the vehicle shop compressed air supply (max. 8 bar / 116.03 psi) to locate possible leaks faster.</p> <p>Hydraulic system</p> <p>Check the pressure hose for leaks.</p>	<p>If the hose leaks, it must be replaced.</p> <p>If the fan leaks, an appropriate seal kit must be ordered.</p>
Mechanical fault	If all the above conditions are met and the blades do not rotate, there is likely a mechanical fault.	<p>Contact the manufacturer.</p> <p>Service address: See section 1.1.2</p>

No or low pressure supply (for electronic components with compressor)

Check	Comment	Action
Check the compressor function.	When the compressor builds up pressure, the voltage may fall to max. 0.5 V below the rated voltage.	If necessary, install the electronic component in a stabler manner (different cross section, shorter cables, etc.).
Check the compressor pressure build-up.	Check the pressure build-up of the compressor (max. 15 s / min. 6.5 bar / 94.27 psi) with the fan connected.	If insufficient pressure is built up, the compressor must be replaced.
Check the valve function.	The valve must click softly when the power supply is switched on and off. If necessary, connect an external power supply. Note: observe voltage of 12 V/ 24 V.	If the valve does not click, it must be replaced.
Check the pressure hose.	If necessary, pull the pressure hose from the valve and connect it to the vehicle shop compressed air supply (max. 8 bar / 116.03 psi) to locate possible leaks faster.	If the hose leaks, it must be replaced. If the fan leaks, an appropriate seal kit must be ordered.
Mechanical fault	If all the above conditions are met and the blades do not rotate, there is likely a mechanical fault.	Contact the manufacturer. Service address: See section 1.1.2

13.2 Blades do not rotate to the cooling position

Fan speed is too high

Check	Comment	Action
Check the reversing function at a reduced speed.	Reducing the speed reduces the aerodynamic force acting on the blades.	Reduce the speed while reversing the fan or install additional springs in the fan. Service address: See section 1.1.2

Fan does not vent / Oil does not flow back

Check	Comment	Action
Check the pressure hose.	The pressure hose must not be bent or pinched.	Eliminate bends and pinch points If the pressure hose is damaged, it must be replaced.
Check the valve function.	The valve must click softly when the power supply is switched on and off. If necessary, connect an external power supply. Note: observe voltage of 12 V/ 24 V.	If the valve does not click, it must be replaced.
Mechanical fault	If the fan with hose disconnected does not switch back in idle, there is likely a mechanical fault.	Contact the manufacturer. Service address: See section 1.1.2

14 Troubleshooting (electronic components)

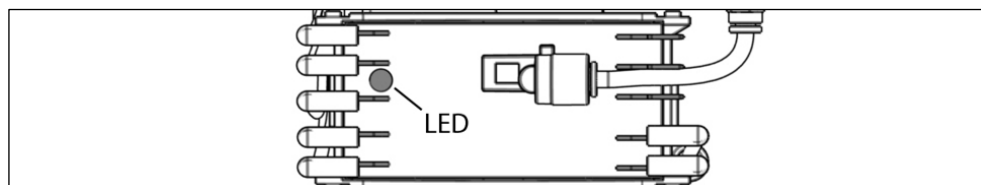









Fig. 98

LED error code	Cause of error
 Does not flash	Check the operating voltage

Green LED error code	Cause of error
 Permanently lit green	Normal status without Bluetooth connection
 Lit green for 3 sec.	Normal status with Bluetooth connection
 Permanently flashing green quickly	[automatic mode] paused <ul style="list-style-type: none"> ▶ In the Cleanfix control app, tap the [▶ resume] button to resume [automatic mode] (see section 11.6).

Red LED error code	Cause of error
 Flashing red 1x	Air filter status is below 10% <ul style="list-style-type: none"> ▶ Pair the device with the Cleanfix control app. ▶ Follow the instructions in the app (see section 11.8).
 Flashing red 2x	Increased temperature <ul style="list-style-type: none"> ▶ Pair the device with the Cleanfix control app. ▶ Acknowledge the error message in the app. The service life of the device is impaired at a temperature of 65° or higher. <ul style="list-style-type: none"> ▶ If necessary, change the installation position of the device.

 <p>Flashing red 3x</p>	<p>The pressure sensor values are faulty</p> <ul style="list-style-type: none"> ▶ Turn the ignition off and on. ▶ If the error persists, contact the manufacturer. <p>Service address: See section 1.1.2</p>
 <p>Flashing red 4x</p>	<p>Short circuit, excess temperature, or broken valve cable</p> <ul style="list-style-type: none"> ▶ Turn the ignition off and on. ▶ If the error persists, contact the manufacturer. <p>Service address: See section 1.1.2</p>
 <p>Flashing red 5x</p>	<p>Short circuit or broken compressor cable</p> <ul style="list-style-type: none"> ▶ Turn the ignition off and on. ▶ If the error persists, contact the manufacturer. <p>Service address: See section 1.1.2</p>
 <p>Permanently flashing red</p>	<p>Critical temperature / temperature shutdown</p> <p>The device switches off at a critical temperature. When the device has cooled off, it switches on again.</p> <ul style="list-style-type: none"> ▶ If the error occurs repeatedly, move the device to a cooler location.
 <p>Permanently flashing red quickly</p>	<p>Short circuit in the push button in the driver's cab or the pressure switch</p> <ul style="list-style-type: none"> ▶ Turn the ignition off and on. ▶ If the error persists, contact the manufacturer. <p>Service address: See section 1.1.2</p>
 <p>Permanently lit red</p>	<p>Multiple error messages present</p> <ul style="list-style-type: none"> ▶ Pair the device with the Cleanfix control app to call up all error messages.

Red/green LED error code	Cause of error
 <p>Permanently flashing alternately red and green</p>	<p>Faulty memory readout</p> <ul style="list-style-type: none"> ▶ Contact the manufacturer. <p>Service address: See section 1.1.2</p>

